

DATA SHEET

15 FRAME PLUNGER PUMPS



**Standard Brass
Model
1530**

**Brass Flushed
Model
1530C**

**Stainless Steel
Model
1531**

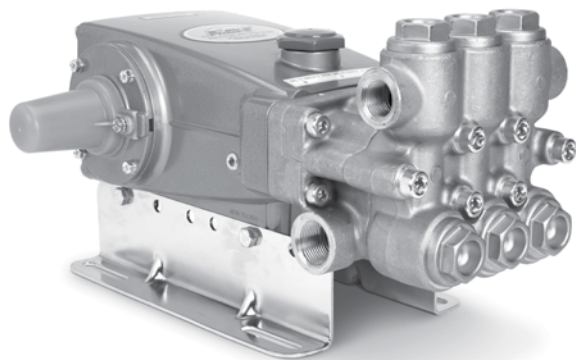

Model 1530 Shown
(Shaft protector and mounting rails
sold separately)

SPECIFICATIONS	U.S. Measure	Metric Measure
Flow	15.6 gpm	59 lpm
Pressure Range	100 to 1500 psi	6.9 to 103 bar
Pump RPM*	1450 rpm	1450 rpm
Inlet Pressure Range	Flooded to 70 psi	Flooded to 4.9 bar
Max. Liquid Temperature	140° F	60° C
Above 130°F call Cat Pumps for inlet conditions and elastomer recommendations.		
Bore	0.984"	25 mm
Stroke	1.181"	30 mm
Crankcase Capacity	42 oz.	1.26 l
Inlet Ports (2)	1" NPT(F)	1" NPT(F)
Discharge Ports (2)	3/4" NPT(F)	3/4" NPT(F)
Flushed Ports (2) (1530C)	1/4" NPT(F)	1/4" NPT(F)
Pulley Mounting	Either Side	Either Side
Shaft Diameter	1.181"	30 mm
Weight (1530, 1530C)	55 lbs.	25 kg
(1531)	53 lbs.	24 kg
Dimensions	17.24 x 13.0 x 7.4"	438 x 330 x 188 mm

*Pump minimum is 100 RPM.

FEATURES

- Triplex plunger design gives smoother liquid flow.
- V-Packings are completely lubricated and cooled by the liquid being pumped.
- Lubricated Lo-Pressure Seals provide double protection against external leakage.
- Special concentric, high-density, polished, solid ceramic plungers provide a true wear surface and extended seal life.
- Special flushed inlet manifold with 1530C permits external flush for added cooling with high temperature liquids and lubrication with low lubricity liquids.
- Standard NBR seals with alternative options for temperature and chemical compatibility
 - FPM – .0110
 - EPDM – .0220

ELECTRIC HORSEPOWER REQUIREMENTS

FLOW		PRESSURE			PUMP RPM
		psi 1000	psi 1200	psi 1500	
gpm	lpm	bar 69	bar 83	bar 103	
15.6	59	10.7	12.8	16.0	1450
14.0	53	9.6	11.5	14.4	1301
12.0	45	8.2	9.9	12.4	1115

$$\text{DETERMINING THE PUMP R.P.M.} \quad \frac{\text{Rated gpm}}{\text{Rated rpm}} = \frac{\text{"Desired" gpm}}{\text{"Desired" rpm}}$$

$$\text{DETERMINING THE REQUIRED H.P.} \quad \text{Hp (Electric Brake)} = \frac{\text{gpm} \times \text{psi}}{1460}$$

$$\text{DETERMINING MOTOR PULLEY SIZE} \quad \frac{\text{Motor Pulley O.D.}}{\text{Pump rpm}} = \frac{\text{Pump Pulley O.D.}}{\text{Motor rpm}}$$

See complete Drive Packages [Includes: pulleys, belts, hubs, key] Tech Bulletin 003.
Refer to pump **Service Manual** for repair procedure and additional technical information.

PARTS LIST

ITEM	PART NUMBER	MATL	PART NUMBER	MATL	DESCRIPTION	QTY
	1530/1530C		1531			
2	990036	STL	990036	STL	Key (M8x7x40)	1
3	30067	STL	30067	STL	Key (M8x7.5x25)	1
5	125824	STCP R	92538	S	Screw, Sems HHC (M6x16)	8
8	43496	AL	43496	AL	Cover, Bearing (See Tech Bulletin 118)	2
10	11340	NBR	11340	NBR	O-Ring, Bearing Cover - 70D	2
11	43495	NBR	43495	NBR	Seal, Oil, Crankshaft - 70D	2
12	815281	FBR	815281	FBR	Shim, Split 2 pc	0-6
13	814800	S	814800	S	Shim, Split 2 pc	0-4
15	39060	STL	39060	STL	Bearing, Roller	2
20	48600	TNM	48600	TNM	Rod, Connecting Assembly	3
25	43494	FCM	43494	FCM	Crankshaft, Dual-End	1
31	828710	PE	828710	PE	Protector, Oil Cap w/Foam Gasket	1
32	43211	ABS	43211	ABS	Cap, Oil Filler	1
33	14177	NBR	14177	NBR	O-Ring, Filler Cap - 70D	1
37	92241	—	92241	—	Gauge, Oil, Bubble w/Gasket - 80D	1
38	44428	NBR	44428	NBR	Gasket, Flat, Oil Gauge - 80D	1
40	126541	STCP R	92542	S	Screw, Sems HHC (M6x20)	4
48	25625	STCP	25625	STCP	Plug, Drain (1/4"x19BSP)	1
49	23170	NBR	23170	NBR	O-Ring, Drain Plug - 70D	1
50	43491	AL	43491	AL	Cover, Rear (See Tech Bulletin 118)	1
51	44834	NBR	44834	NBR	O-Ring, Rear Cover - 70D	1
53	115471	AL	115471	AL	Crankcase w/Guide Pins (See Tech Bulletin 118)	1
56	44664	POP	44664	POP	Pan, Oil	1
64	43507	CM	43507	CM	Pin, Crosshead	3
65	48228	SHS	48360	SSHS	Rod, Plunger	3
69	126592	STCP R	126592	STCP R	Washer, Oil Seal	3
70	43500	NBR	43500	NBR	Seal, Oil Crankcase - 80D	3
75	43506	S	43506	S	Slinger, Barrier	3
90	48606	CC	48606	CC	Plunger, Ceramic (M25x92)	3
96	43235	PTFE	43235	PTFE	Back-up-Ring, Plunger Retainer	3
95	—	—	89651	SS	Stud, Plunger Retainer (M6x70)	1
97	17399	NBR	17399	NBR	O-Ring, Plunger Retainer - 80D	3
	14160	FPM	14160	FPM	O-Ring, Plunger Retainer - 80D	3
	◆ 46204	EPDM	◆ 46204	EPDM	O-Ring, Plunger Retainer - 70D	3
98	45891	CU	44041	SS	Gasket, Plunger Retainer	3
99	104360	S	44031	SS	Retainer, Plunger	3
100	899509	POP	899509	POP	Retainer, Seal 2-Pc [07/06]	3
101	48716	—	48716	—	Wick, Long Tab	3
106	44086	NBR	44086	NBR	Seal, LPS w/SS-Spg	3
	45846	FPM	45846	FPM	Seal, LPS w/SS-Spg	3
	◆ 49196	EPDM	◆ 49196	EPDM	Seal, LPS w/SS-Spg	3
110	48608	FBB	48683	SS	Manifold, Inlet	1
	48608C	FBB	—	—	Manifold, Inlet Flushed [1/4" NPT(F) Port]	1
112	14200	NBR	14200	NBR	O-Ring, Inlet Manifold - 70D	3
	11719	FPM	11719	FPM	O-Ring, Inlet Manifold	3
	◆ 48907	EPDM	◆ 48907	EPDM	O-Ring, Inlet Manifold	3
117	126515	STCP R	87952	S	Screw, HSH (M10x55)	4
126	48538	BB	48669	D	Adapter, Female	3
	—	—	76667	ss	Adapter, Female	3
127	44610	STG	44610	STG	V-Packing	6
128	48539	BB	113025	SS	Adapter, Male	3
141	48672	SS	48672	SS	Spring, Coil [12/02]	18
142	48550	BB	48670	SS	Spacer w/Coil Springs	3
155	17629	NBR	17629	NBR	O-Ring, Spacer - 80D	6
	14183	FPM	14183	FPM	O-Ring, Spacer	6
	◆ 701491	EPDM	◆ 701491	EPDM	O-Ring, Spacer - 70D	6
156	28243	PTFE	28243	PTFE	Back-up-Ring, Spacer	6
162	48363	D	48363	D	Back-up-Ring, Seat	6
163	26142	NBR	26142	NBR	O-Ring, Seat - 80D	6
	14330	FPM	14330	FPM	O-Ring, Seat	6
	◆ 701493	EPDM	◆ 701493	EPDM	O-Ring, Seat	6
164	48596	S	48688	SS	Seat, Q.V. Stepped	6
166	48686	SS	48686	SS	Valve, Q.V.	6
167	48687	SS	48687	SS	Spring, Valve [12/02]	6
168	44735	PVDF	44735	PVDF	Retainer, Spring	6
170	44794	SS	44794	SS	Washer, Spring Retainer	6
171	48689	SS	48689	SS	Spring, Coil [12/02]	6
172	17629	NBR	17629	NBR	O-Ring, Valve Plug - 80D	6
	14183	FPM	14183	FPM	O-Ring, Valve Plug	6
	◆ 701491	EPDM	◆ 701491	EPDM	O-Ring, Valve Plug - 70D	6
174	48597	FBB	49294	SS	Plug, Valve	6
185	48610	FBB	48685	SS	Manifold, Discharge	1
188	126519	STCP R	89981	SS	Screw, HSH (M12x70)	6
250	30764	NY	30764	NY	Protector, Shaft w/2 Screws	1
260	30613	STZP	30613	STZP	Rail, Angle Assy	1

EXPLODED VIEW

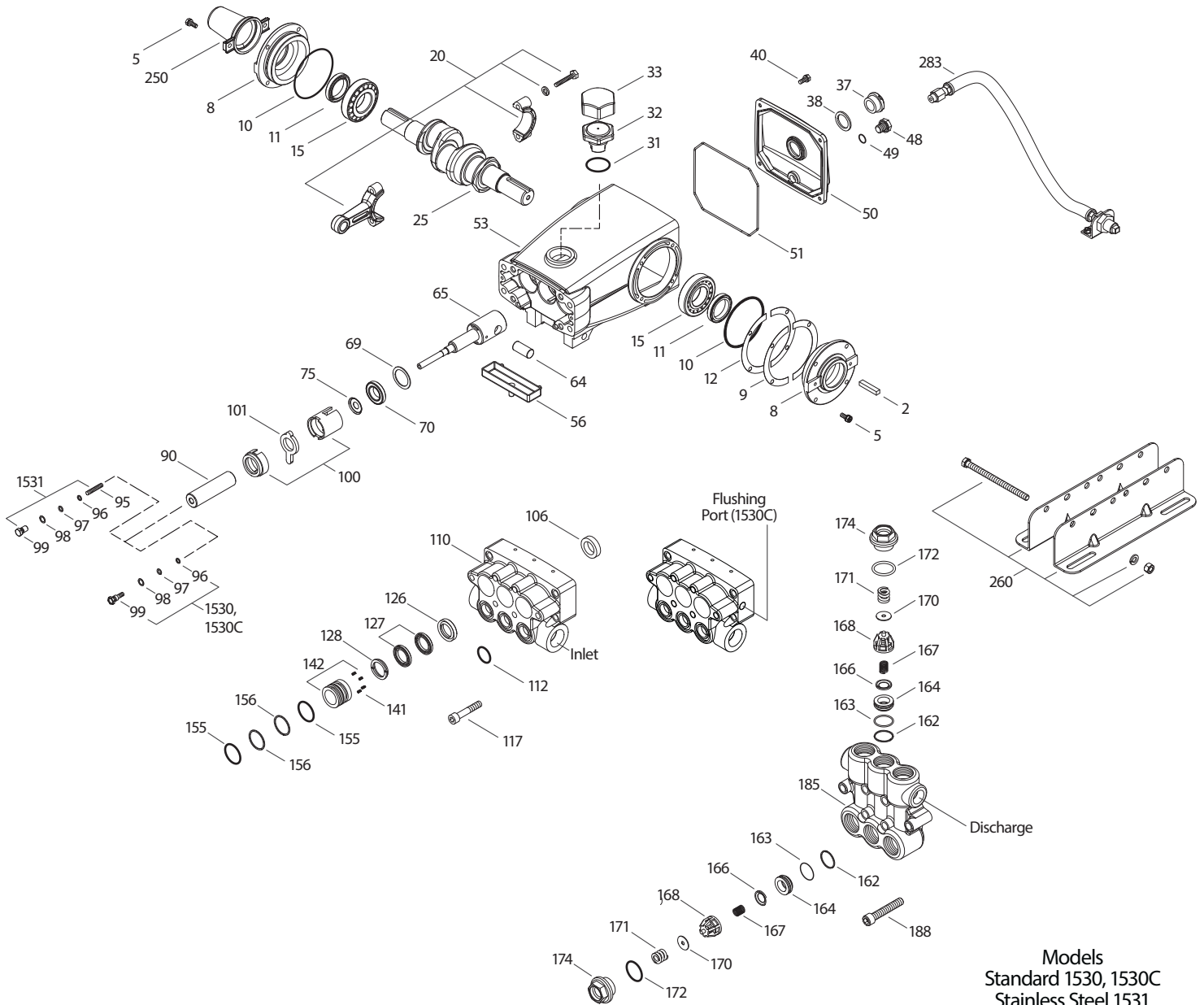

Models
Standard 1530, 1530C
Stainless Steel 1531
December 2016

ITEM	PART NUMBER	MATL	PART NUMBER	MATL	DESCRIPTION	QTY
	1530/1530C		1531			
269	30206	F	30206	F	Pulley, 10" 2 groove "H" [See Tech Bulletin 003] (Not Shown)	1
270	30059	STL	30059	STL	Hub, "H", M30 (Keyway M8) [See Tech Bulletin 003] (Not Shown)	1
	990012	STL	990012	STL	Hub, "B", M30 (Keyway M8) [See Tech Bulletin 003] (Not Shown)	1
283	34334	—	34334	—	Kit, Oil Drain	1
290	6124	—	6124	—	Liquid Gasket, Hylomar (3 oz.)	1
299	816762	FBB	816783	SS	Head, Complete w/NBR Seals and O-Rings (Models 1530 and 1531 only)	1
300	31355	NBR	31355	NBR	Kit, Seal (Incls: 97,106,112,127,155,156) - Standard	1
	31455	FPM*	31455	FPM*	Kit, Seal (Incls: 97,106,112,127,155,156) - .0110	1
	◆ 31753	EPDM	◆ 31753	EPDM	Kit, Seal (Incls: 97,106,112,127,155,156) - .0220	1
310	31360	NBR	31271	NBR	Kit, Valve (Incls: 162,163,164,166,167,168,170,172) - Standard	2
	31460	FPM	31281	FPM	Kit, Valve (Incls: 162,163,164,166,167,168,170,172) - .0110	2
	◆ 31773	EPDM	◆ 31773	EPDM	Kit, Valve (Incls: 162,163,164,166,167,168,170,172) - .0220	2
—	6100	—	6100	—	Oil, Case (12 Bottles) ISO 68 Hydraulic (Fill to specified crankcase capacity prior to start-up)	1
—	—	—	6119	—	Lubricant, Antiseize (2 oz.) (See Tech Bulletin 095)	1

Bold print part numbers are unique to a particular pump model. Italics are optional items. [] Date of latest production change.

◆ Silicone oil/grease required. R Components comply with RoHS Directive. * Review material codes for individual items (STG generally may be used as alternate).

See Tech Bulletins 002, 003, 024, 035, 036, 043, 053, 074, 083, 085, 095, 098 and 118 for additional information.

MATERIAL CODES (Not Part of Part Number): ABS=ABS Plastic AL=Aluminum BB=Brass CC=Ceramic CM=Chrome-moly CU=Copper D=Acetal EPDM=Ethylene Propylene Diene Monomer F=Cast Iron FBB=Forged Brass FBR=Fiber FCM=Forged Chrome-moly FPM=Fluorocarbon NBR=Medium Nitrile (Buna-N) NY=Nylon PE=Polyethylene POP=Polypropylene PTFE=Pure Polytetrafluoroethylene PVDF=Polyvinylidene Fluoride S=304SS SHS=304SS/High Strength SS=316SS SSHS= 316SS/High Strength STCP=Steel/Chrome Plated STG=Special Blend PTFE White STL=Steel STZP=Steel/Zinc Plated TNM=Special High Strength

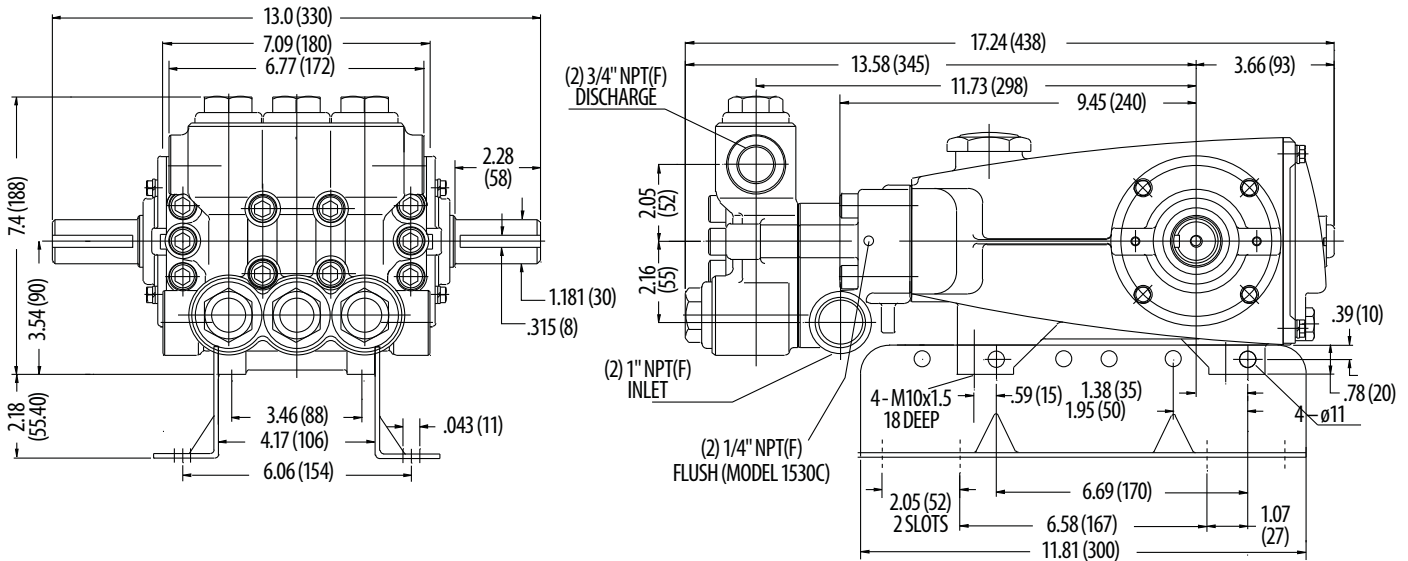

⚠ CAUTIONS AND WARNINGS

All High Pressure Systems require a primary pressure regulating device (i.e. regulator, unloader) and a secondary pressure relief device (i.e. pop-off valve, relief valve). Failure to install such relief devices could result in personal injury or damage to pump or property. Cat Pumps does not assume any liability or responsibility for the operation of a customer's high pressure system.

Read all CAUTIONS and WARNINGS before commencing service or operation of any high pressure system. The CAUTIONS and WARNINGS are included in each service manual and with each Accessory Data sheet. CAUTIONS and WARNINGS can also be viewed online at www.catpumps.com/cautions-warnings or can be requested directly from Cat Pumps.

WARRANTY

View the Limited Warranty on-line at www.catpumps.com/warranty.



CAT PUMPS

1681 - 94TH LANE N.E. MINNEAPOLIS, MN 55449-4324
 PHONE (763) 780-5440 — FAX (763) 780-2958
 e-mail: techsupport@catpumps.com
www.catpumps.com