

Model 3CP1120.44101 Shown
(Rails and shaft protector sold separately)

3CP Plunger Pump

**Triethylene Glycol
(TEG) Dehydration**

Models
3CP1120.44101
3CP1130.44101
3CP1140.44101

FEATURES

- Designed for continuous-duty performance for triethylene glycol (TEG) gas dehydration where low life cycle costs are a must.
- Field tested, high pressure triplex pump configured for TEG temperatures up to 240° F (116° C).
- Positive displacement technology for optimum energy efficiency.
- Compact footprint enhances direct-drive gearbox and bell housing drives.

COMMON SPECIFICATIONS

Inlet Pressure Range.....	Flooded to 70 psi	(Flooded to 4.9 bar)
Bore	0.709"	(18 mm)
Crankcase Capacity.....	11.8 oz.	(0.35 l)
Maximum Liquid Temperature	240°F	(116°C)
Inlet Ports (2)	1/2" NPTF	(1/2" NPTF)
Discharge Ports (2).....	3/8" NPTF	(3/8" NPTF)
Pulley Mounting	Either Side	(Either Side)
Shaft Diameter	0.650"	(16.5 mm)
Weight.....	14.84 lbs.	(6.7 kg)
Dimensions.....	9.32 x 8.78 x 6.75" (237 x 223 x 171 mm)	

⚠ CAUTIONS AND WARNINGS

All High Pressure Systems require a primary pressure regulating device (i.e. regulator, unloader) and a secondary pressure relief device (i.e. pop-off valve, relief valve). Failure to install such relief devices could result in personal injury or damage to pump or property. CAT PUMPS does not assume any liability or responsibility for the operation of a customer's high pressure system.

Read all CAUTIONS and WARNINGS before commencing service or operation of any high pressure system. The CAUTIONS and WARNINGS are included in each service manual and with each Accessory Data sheet. CAUTIONS and WARNINGS can also be viewed online at www.catpumps.com/cautions-warnings or can be requested directly from CAT PUMPS.

WARRANTY

View the Limited Warranty on-line at www.catpumps.com/warranty.

SPECIFICATIONS

U.S. Measure Metric Measure

MODEL 3CP1120.44101 DIRECT DRIVE

Flow.....	4.2 gpm	(16 lpm)
Pressure Range.....	100 to 2200 psi	(7 to 155 bar)
RPM.....	1725 rpm	(1725 rpm)
Stroke.....	0.500"	(12.7 mm)

MODEL 3CP1130.44101 DIRECT DRIVE

Flow.....	2.4 gpm	(9 lpm)
Pressure Range.....	100 to 2200 psi	(7 to 155 bar)
RPM.....	1725 rpm	(1725 rpm)
Stroke.....	0.276"	(7 mm)

MODEL 3CP1140.44101 DIRECT DRIVE

Flow.....	3.6 gpm	(13.6 lpm)
Pressure Range.....	100 to 2200 psi	(7 to 155 bar)
RPM.....	1725 rpm	(1725 rpm)
Stroke.....	0.433"	(11 mm)

ELECTRIC HORSEPOWER REQUIREMENTS

MODELS	FLOW		PRESSURE					MOTOR PULLEY SIZE Using 1750 rpm Motor 5.0" Pump Pulley O.D.
			psi 1200	psi 1500	psi 2000	psi 2200	rpm	
	U.S. gpm	l/m	bar 85	bar 105	bar 140	bar 155		
3CP1120.44101	4.2	16	35	4.3	5.8	6.3	1725	Pulley O.D. 5.0
	3.5	13.2	2.9	3.6	4.8	5.3	1531	4.4
	3.0	11.4	2.5	3.1	4.2	4.5	1313	3.8
3CP1130.44101	2.4	9	1.9	2.4	3.2	3.6	1725	Direct Drive
3CP1140.44101	3.6	13.6	3.0	3.7	5.0	5.4	1725	Direct Drive

DETERMINING THE PUMP R.P.M.	Rated gpm	=	"Desired" gpm
	Rated rpm	=	"Desired" rpm
DETERMINING THE REQUIRED H.P.	gpm x psi	=	Electric Brake
	1460	=	H. P. Required
DETERMINING MOTOR PULLEY SIZE	Motor Pulley O.D.	=	Pump Pulley O.D.
	Pump rpm	=	Motor rpm

See complete Drive Packages [Incls: Pulleys, Belts, Hubs, Key] Tech Bulletin 003.
Refer to pump **Service Manual** for repair procedure and additional technical information.

PARTS LIST

ITEM	PART NUMBER	MATL	DESCRIPTION	QTY
5	125824	STCP R	Screw, HHC Sems (M6x16)	8
8	46901	AL	Cover, Bearing	2
10	76028	FPM	O-Ring, Bearing Cover - 70D	2
11	76236	FPM	Seal, Oil, Crankshaft - 70D	2
15	14480	STL	Bearing, Ball	2
20	48730	TNM	Rod, Connecting, Assembly	3
25	46927	FCM	Crankshaft, Dual End - 3CP1120.44101 (M12.7)	1
	46994	FCM	Crankshaft, Dual End - 3CP1130.44101 (M7)	1
	46991	FCM	Crankshaft, Dual End - 3CP1140.44101 (M11)	1
31	76142	AL	Adapter, Breather	1
32	76797	BB	Cap, Vented	1
36	76792	SS	Gauge, Sight	1
37	76791	AL	Adapter, Sight	1
38	44428	NBR	Gasket, Flat, Adapter - 80D	1
40	125824	STCP R	Screw, HHC Sems (M6x16)	4
48	25625	STCP	Plug, Drain (1/4"x19BSP)	1
49	30322	FPM	O-Ring, Drain Plug	1
50	46939	AL	Cover, Rear	1
51	76241	FPM	O-Ring, Rear Cover	1
53	48644	AL	Crankcase	1
64	46615	CM	Pin, Crosshead	3
65	48459	BBNP	Rod, Plunger	3
70	76739	FPM	Seal, Oil, Crankcase	3
75	43900	S	Slinger, Barrier	3
88	45697	S	Washer, Keyhole	3
90	46976	CC	Plunger (M18x43)	3
98	48394	FPM	Washer, Seal - 90D	3
99	† 48201	SS	Retainer, Plunger w/Stud (M6)	3
100	76541	AL	Retainer, Seal	3
106	76243	ST2	Seal, LPS w/S-Spg	3
120	46625	BB	Case, Seal	3
121	48522	FPM	O-Ring, Seal Case	3
125	76052	ST4	Seal, HPS w/S	3
139	43448	BB	Plug, Inlet (1/2"NPT)	1
163	11685	FPM	O-Ring, Seat - 85D	6
164	45790	S	Seat	6
166	43723	S	Valve	6
167	43750	S	Spring	6
168	44565	PVDF	Retainer, Spring	6
172	15855	FPM	O-Ring, Valve Plug - 70D	6
174	46756	BB	Plug, Valve	6
185	46616	FBB	Manifold, Head	1
188	126512	STCP R	Screw, HSH (M8x65)	8
196	22187	BBCP	Plug, Discharge (3/8"NPT)	1

Optional Parts And Accessories On Page 4

Bold print part numbers are unique to a particular pump model. [] Date of latest production change.

† Production parts are different than repair parts. R Components comply with RoHS Directive.

View Tech Bulletins 002, 003, 024, 036, 064, 073, 074, 083 for additional information.

For motorized versions see BD motor data sheet. For Gearbox version see 8075 data sheet.

MATERIAL CODES (Not Part of Part Number): AL=Aluminum BB=Brass BBCP=Brass/Chrome Plated BBNP=Brass Nickel Plated CC=Ceramic
 CM=Chrome-moly FBB=Forged Brass FCM=Forged Chrome-Moly FPM=Fluorocarbon NBR=Medium Nitrile (Buna-N)
 PVDF=Polyvinylidene Fluoride S=304SS ST4= Special PTFE 4 STL=Steel STCP=Steel/Chrome Plated
 TNM=Special High Strength

EXPLODED VIEW

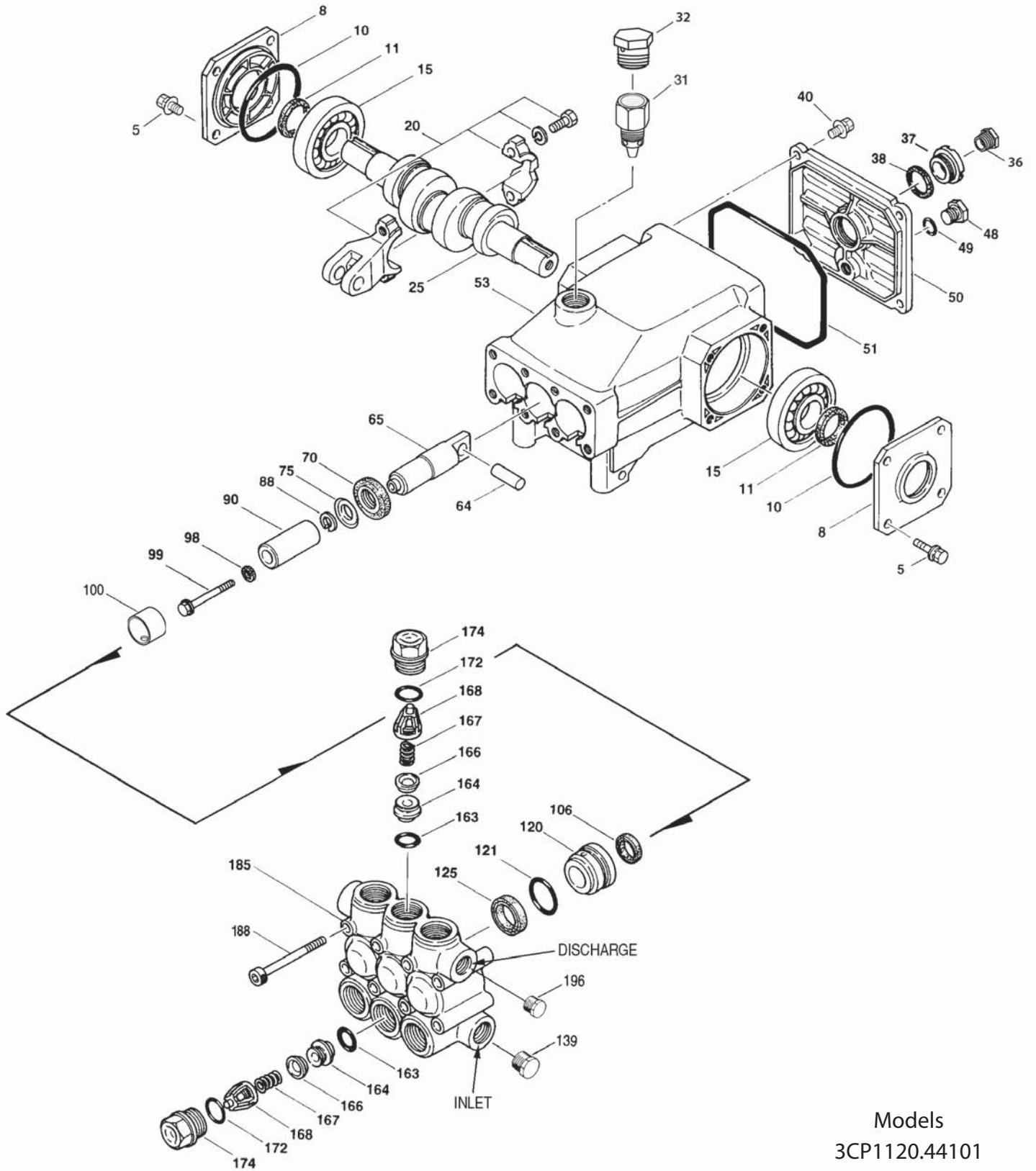

Models
3CP1120.44101
3CP1130.44101
3CP1140.44101
November 2011

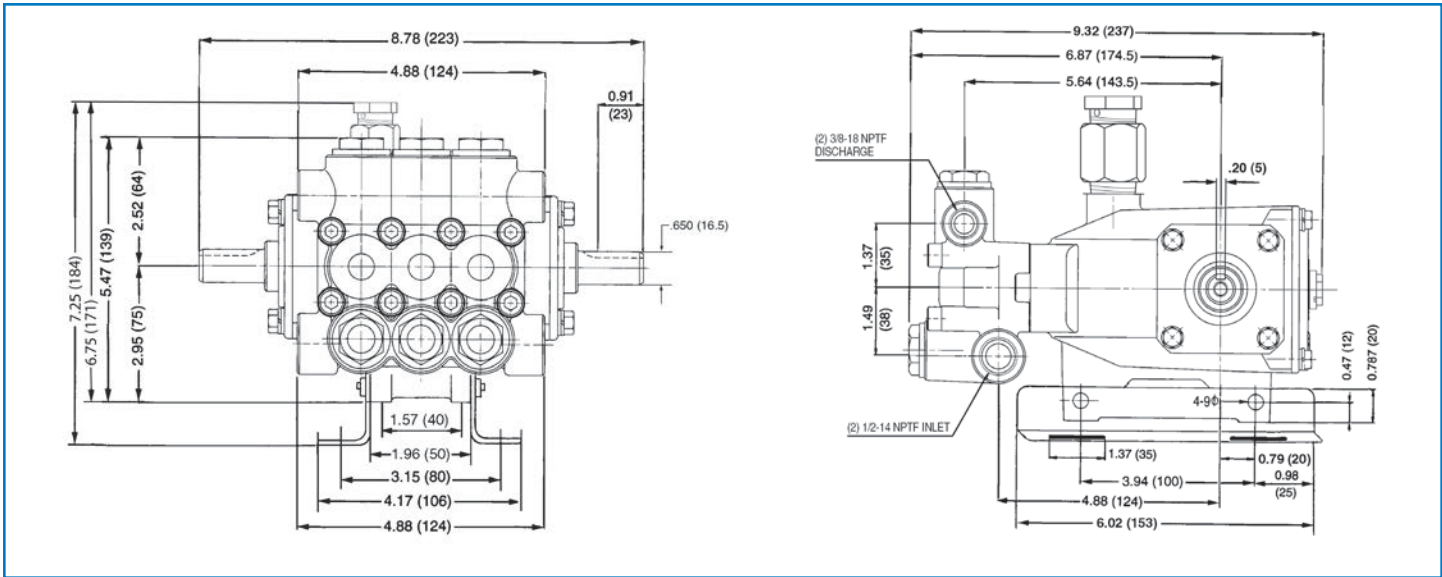

Models 3CP1120.44101, 3CP1130.44101, 3CP1140.44101

OPTIONAL PARTS AND ACCESSORIES

Part Number	Description	QTY		
7003	Regulator (Primary Pressure Control)	1		
7672.0110	Unloader (Primary Pressure Control)	1		339615
7672.1110	Relief Valve (Secondary Pressure Control)	1	7003	
339615	Pop-Off Valve (Secondary Pressure Control)	1		6030
6073	Pressure Gauge	1	7672.0110	
6030	Accumulator	1	7672.1110	
30612	Mounting Rails	1		
118672	Shaft Protector	1	118672	
30047	Key (M5x5x24)	1		
76334	Kit, Oil Indicator (3/8" x 24") See Individual Data Sheet	1		
34334	Kit, Oil Drain (3/8" x 24") See Individual Data Sheet	1		
76097	Kit, Seal (Includes Items 98, 106, 121, and 125)	1	76097	
33258	Kit, Valve (Includes Items 163, 164, 166, 167, 168 and 172)	1		
814841.44101	Complete Head	1		
30696	Pliers (Reverse)	1		
44050	Tool, Sight Gauge Removal	1		
6107	Oil, Bottle (21 oz.) ISO 68 Hydraulic	1	6107	
				30612

Demand Genuine Cat Pump Parts And Accessories.



CAT PUMPS
 1681 - 94TH LANE N.E. MINNEAPOLIS, MN 55449-4324
 PHONE (763) 780-5440 — FAX (763) 780-2958
 e-mail: techsupport@catpumps.com
 www.catpumps.com