



Prrrr-O-Lator Pulsation Dampeners

ORDERING INFORMATION

Use base part number for rechargeable models 6013, 6014, or 6015 if factory pre-charge is desired.

Add .800 to base part number for rechargeable models (i.e. 6013.800) for:

1. No pre-charge (remove factory pressure)
2. A pre-charge different from factory (indicate desired pre-charge on purchase order)

Note: A handling charge will apply.

SPECIFICATIONS

	U.S. Measure	Metric Measure
MODEL 6013 - Rechargeable		
Maximum Flow.....	40 gpm	(151 lpm)
Maximum Working Pressure.....	2000 psi	(140 bar)
Precharge.....	.450 psi	(30 bar)
Temperature Range.....	+5° to 300°F	(-15 to 149°C)
Volume.....	45 cu. in.	(0.74 l)
Safety Factor.....	4/1	(4/1)
Bladder Construction.....	FPM	(FPM)
Port Size.....	1" NPTM	(1" NPTM)
Diameter.....	4.44"	(113 mm)
Length.....	7.79"	(198 mm)
Weight.....	6.28 lbs.	(2.8 kg)

MODEL 6014 - Rechargeable

Maximum Flow.....	25 gpm	(95 lpm)
Maximum Working Pressure.....	2400 psi	(170 bar)
Precharge.....	.450 psi	(30 bar)
Temperature Range.....	+5° to 180°F	(-15 to 82°C)
Volume.....	20 cu. in.	(0.328 l)
Safety Factor.....	4/1	(4/1)
Bladder Construction.....	NBR	(NBR)
Port Size.....	3/4" NPTM	(3/4" NPTM)
Diameter.....	3.66"	(93 mm)
Length.....	5.91"	(150 mm)
Weight.....	2.9 lbs.	(1.31 kg)

MODEL 6015 - Rechargeable

Maximum Flow.....	70 gpm	(265 lpm)
Maximum Working Pressure.....	1500 psi	(105 bar)
Precharge.....	.450 psi	(30 bar)
Temperature Range.....	+5° to 180°F	(-15 to 82°C)
Volume.....	120 cu. in.	(1.97 l)
Safety Factor.....	4/1	(4/1)
Bladder Construction.....	NBR	(NBR)
Port Size.....	1-1/4" NPTM	(1-1/4" NPTM)
Diameter.....	6.30"	(160 mm)
Length.....	9.0"	(229 mm)
Weight.....	9.3 lbs.	(4.2 kg)

FEATURES

- Nitrogen precharged to eliminate moisture and bladder deterioration.
- Broader bladder design provides greater pulsation reduction for smoother performance and longer system component life.
- 316 Stainless Steel housing for critical applications.
- Sealed valve for positive pressure lock.

SHIPMENT REGULATIONS

- Pre-charged Prrrr-O-Lators are defined as hazardous articles. Uncharged Prrrr-O-Lators requires no special handling and can be shipped via standard shipping methods.
- All domestic shipments of hazardous articles must follow Department of Transportation CFR 49, parts 100 to 185 regulations (DOT).
- International shipments of hazardous articles must follow either International Air Transport Association regulation (IATA) or International Maritime Dangerous Goods Codes (IMDG).

⚠ CAUTIONS AND WARNINGS

All High Pressure Systems require a primary pressure regulating device (i.e. regulator, unloader) and a secondary pressure relief device (i.e. pop-off valve, relief valve). Failure to install such relief devices could result in personal injury or damage to pump or property. CAT PUMPS does not assume any liability or responsibility for the operation of a customer's high pressure system.

Read all CAUTIONS and WARNINGS before commencing service or operation of any high pressure system. The CAUTIONS and WARNINGS are included in each service manual and with each Accessory Data sheet. CAUTIONS and WARNINGS can also be viewed online at www.catpumps.com/cautions-warnings or can be requested directly from CAT PUMPS.

WARRANTY

View the Limited Warranty on-line at www.catpumps.com/warranty.

INSTALLATION INSTRUCTIONS

⚠ WARNING

Do not charge Prrrrr-O-Lators (Pulsation Dampeners) with oxygen. Oxygen may cause an explosion causing personal injury, death or property damage.

1. Use nitrogen only when charging pulsation dampeners, DO NOT USE OXYGEN.
2. Use proper charging tools to charge pulsation dampeners.
3. Charge pulsation dampener within specifications stated on data sheet to assure proper pulsation dampening and prevent failure of bladder.

SELECTION: The Prrrrr-O-Lator should be selected to match the flow and pressure requirements of the system and satisfy the liquid compatibility.

INSTALLATION: The Prrrrr-O-Lator should be mounted directly onto the pump discharge manifold for optimum pulsation dampening and to avoid system vibration damage.

OPERATION: The Prrrrr-O-Lator should be precharged with **dry Nitrogen only**.

The Prrrrr-O-Lator is standardly precharged to 450 PSI, however, it may be adjusted to offer a more precise control of pulsation in critical applications such as reverse osmosis.

At a standard temperature of 70°F, optimum accumulator performance is obtained when the precharge is calibrated at 50% of the system operating pressure.

Note: When operating at the lower temperatures, precharge should be 15% higher or 65% of system pressure. When operating at higher temperatures, precharge should be 15% lower or 35% of system pressure.

Note: Up to 50 PSI precharge pressure can be lost during the checking of your precharge.

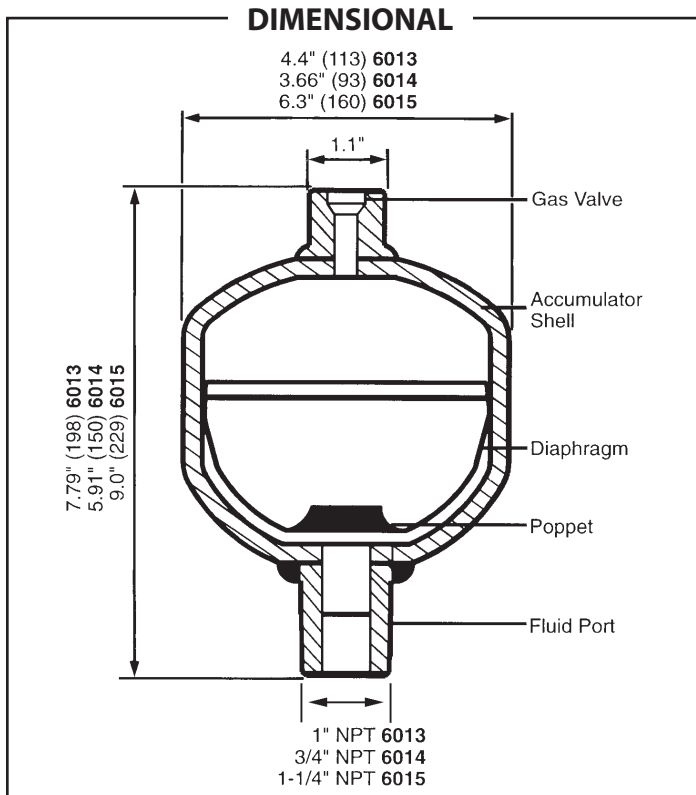

FILLING AND GAUGING INSTRUCTIONS

The following are the steps in both checking the precharge of the accumulator and recharging if there should be a loss of pressure or a need for adjustment.

NOTE: A gas regulator must be mounted between the nitrogen tank and the hose connection from the Filling and Gauging Assembly to enable you to regulate the precharge and to prevent excessive pressure being transmitted directly to the Prrrrr-O-Lator. OVER PRESSURIZATION WILL VOID THE WARRANTY.

1. Before checking your precharge, **system pressure should be at zero**. TURN SYSTEM OFF.
2. SLIGHTLY loosen the sealed valve at the top of the accumulator using a 6mm long handled allen wrench. Thread on the Filling and Gauging Assembly hand tight.
3. Be certain the SIDE BLEED VALVE on the gauging assembly is CLOSED.
4. Slowly open the LARGE "T" VALVE at the top of the gauging assembly until completely open. The gauge on the assembly will read the precharge on the accumulator.
5. Completely back off (CLOSE) the valve on the gas regulator, open the nitrogen tank valve and read the nitrogen tank pressure on the first gauge.
6. If the reading on the gauge assembly is 50% of the system pressure, close the top "T" valve and proceed to step 9.
7. If the precharge is too high, keep the top "T" valve open and slowly open the small "T" valve on the side of the gauging assembly to bleed off pressure.
8. If the pressure is less than 50% of the system pressure, slowly open the gas regulator valve until the desired precharge is reached on the second gauge.
9. When the gauge reads the required precharge, close the "T" valve on the top of the gauging assembly to lock the precharge in the accumulator.
10. Back off (CLOSE) the gas regulator.
11. Proceed with opening the small side "T" valve on the gauging assembly to relieve (bleed-off) pressure in the assembly and on the second gauge on the gas regulator.
12. Close the side "T" valve on the gauging assembly and remove the assembly from the accumulator.
13. Tighten the accumulator sealed valve and resume operation.

- 30940 Complete Filling and Gauging Assembly (Optional)
- 30941 Allen Wrench (Included in Assembly)
- 6099 Pressure Gauge 1/8" BSP, 3500 PSI Backmount (Included in Assembly)



CAT PUMPS

1681 - 94TH LANE N.E. MINNEAPOLIS, MN 55449-4324
PHONE (763) 780-5440 — FAX (763) 780-2958
e-mail: techsupport@catpumps.com
www.catpumps.com