

DATA SHEET

PRESSURE REGULATOR



Stainless Steel **7410**
Model:



FEATURES

- Flow-through design for easy installation.
- Unique high velocity design assures consistent pressure for multiple pump, gun or nozzle installations.
- All metal wear parts are stainless steel; all elastomers are FPM for durability.
- Adjusting nut allows easy calibrated pressure adjustment.
- Multiple regulators can be installed in parallel to handle larger volumes.
- No external moving parts or springs.

COMMON SPECIFICATIONS

	U.S.	Metric
Flow Range	10 - 100 gpm	38 - 378 lpm
Pressure Range	100 - 1500 psi	6.9 - 103 bar
Max Temperature	240° F	115° C
Inlet/Outlet Ports	1-1/2" NPT(F)	1-1/2" NPT(F)
By-Pass Port	2" NPT(F)	2" NPT(F)
Accessory Port	1/4" NPT(F)	1/4" NPT(F)
Weight	14.8 lbs.	6.7 kg
Dimensions	3.25 x 11.42"	82.6 x 290 mm

Read all CAUTIONS and WARNINGS before commencing service or operation of any high-pressure system

SELECTION

This pressure regulator is designed for systems with single or multiple pumps, solenoid (gate) valves, nozzles, and standard or “weep” guns.

Note: For multiple pump systems, it is best to use a pressure regulator not a pressure sensitive regulating unloader.

This regulator should meet both the desired system flow (combined nozzle flow rate requirement) and the desired system pressure.

Note: Operation below the minimum flow of the regulator causes the regulator to cycle or chatter. Operation above the maximum flows of the regulator causes premature regulator wear, regulator cycling and prevents attaining desired system pressure.

INSTALLATION

This regulator operates properly when mounted in any direction; however, it is preferred to keep the plumbing to a minimum and the pressure adjusting nut easily accessible. The best mounting location is directly on the pump discharge manifold head. Use flexible, high pressure hose (minimum single wire braid) at least the size of the regulator ports when plumbing to and from the regulator.

Since this is a flow through design regulator, the inlet and discharge connections are interchangeable and are located on the sides. An arrow on the label indicates liquid flow in either direction. Plumb into one side for inlet flow from pump and plumb opposite side to the discharge line with spray guns, solenoid (gate) valves or nozzles.

The by-pass connection of this regulator is located on the bottom. An arrow on the label indicates the direction of flow. By-pass liquid is directed out this port and can be routed to a reservoir (preferred method), or to a drain or back to the pump inlet.

OPERATION

This pressure regulator maintains established system pressure in the discharge line and at the pump head when the trigger gun is closed or solenoid (gate) valve is closed or the nozzle is clogged, thus by-passing all unrequired flow. Squeezing the trigger gun or opening the solenoid (gate) valve allows for a quick return to established system pressure.

PRESSURE ADJUSTMENT

1. Setting and adjusting the regulator pressure must be done with the system “on”.
2. Start the system with regulator backed off to the lowest pressure setting (counterclockwise direction).
3. Squeeze the trigger and read the pressure on the gauge at the pump.
Note: Do not read the pressure at the gun or nozzle.
4. If more pressure is desired, release the trigger, turn adjusting nut one quarter turn in clockwise direction.
5. Squeeze the trigger and read the pressure.
6. Repeat this process until desired system pressure is attained.
7. Once the desired system pressure is reached, stop turning the adjusting nut.

Note: A minimum by-pass flow of 10% of the regulator rated flow is required for proper regulator performance. If the entire output is directed through the nozzles (zero by-pass) the “cushioning” feature of the by-pass liquid is eliminated and the regulator can malfunction or wear prematurely.

8. If desired system pressure cannot be reached, review TROUBLESHOOTING chart.
9. When servicing existing systems, back off lock nut.
10. Follow adjustment procedures as stated above for new regulators.

Note: Do not adjust regulators pressure setting to compensate for a worn nozzle. Check the nozzle as part of the regular maintenance and replace if worn.

Note: A secondary pressure relief device (i.e., pop-off valve) should be used along with this pressure regulator. Final adjustment for the relief valve should relieve at 200 psi above the system operating pressure.

TYPICAL REGULATOR INSTALLATION

1. Pressure Gauge
2. Relief Valve (shown as a secondary relief valve)
3. Pulsation Dampener
4. Pressure Regulator
5. Triplex Plunger Pump

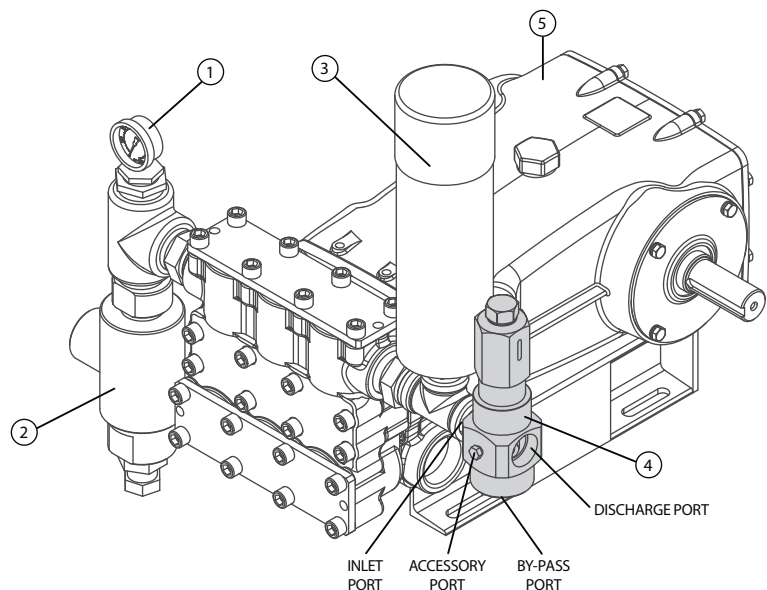

Read all CAUTIONS and WARNINGS before commencing service or operation of any high-pressure system

SERVICING

CAUTION: Before commencing with service, shut off drive (electric motor, gas or diesel engine) and turn off water supply to pump. Relieve all discharge line pressure by triggering gun or opening valve in discharge line.

Disassembly

1. Disconnect by-pass, discharge and inlet plumbing from regulator.
2. Remove regulator from pump.
3. Secure lower body of regulator in a vise with adjusting nut facing up.
4. Remove upper body by unthreading from lower body.
5. Grasp top of piston stem and separate from conical piston.
6. Remove piston stem with stack of spring washers, flat washers and anti-rotating washer and place on flat surface.
7. Remove conical piston with reverse pliers by making contact on the inside diameter of conical piston.

CAUTION: Exercise extreme caution to avoid contact and damage to outside diameter and sharp tip of conical piston.

8. Remove piston retainer from lower body of regulator.

CAUTION: Exercise extreme caution to avoid contact and damage to the inside diameter of the piston retainer.

9. Remove conical seat from lower body of regulator.

CAUTION: Exercise extreme caution to avoid contact and damage to outside diameter and the tapered surface of the seat.

Note: With the regulator completely disassembled, inspect lower body sealing areas where the conical seat and piston retainer makes contact for grooves, pitting and wear. If damage is found, replace with new lower body or complete new regulator. If not, proceed with reassembly.

Reassembly

Note: Spring washers and flat washers should be changed as a spring set.

1. Place lower regulator body with by-pass port facing down into a vise.
2. Lubricate and install o-ring onto outside diameter of conical seat. Press conical seat down into lower regulator body with small hole facing up.
3. Lubricate and install o-ring onto piston retainer. Press piston retainer with raised surface facing up.
4. Lubricate and install back-up-ring, then o-ring onto outside diameter of conical piston. Press conical piston with sharp point down into piston retainer.
5. Replace piston stem with stack of spring washers and flat washers into hole of conical piston.
6. Place anti-rotating washer on top of spring set. Align tabs on washer with slots on the upper body.

Note: Model 7410 has a spring set of 22 spring washers and four flat washers. Place three flat washers between the anti-rotating washer and spring stack, and one flat washer between spring stack and retaining ring.

7. Thread upper body into lower body.
8. Re-install regulator onto pump.
9. Reconnect by-pass, discharge and inlet plumbing to regulator.
10. Proceed to PRESSURE ADJUSTMENT.

TROUBLE SHOOTING

Cycling/Chattering	<ul style="list-style-type: none"> • Air in system, poor connections. • Inlet seals in pump worn. • O-ring in gun worn.
System will not build up to pressure	<ul style="list-style-type: none"> • Nozzle worn. • Improper nozzle size for system specs. • Foreign material trapped in seat.
Pressure drop	<ul style="list-style-type: none"> • Nozzles worn. • Piston and seat in regulator worn. • Air in system, poor connections. • Insufficient flow to pump. • Filter clogged. Check and clean regularly. • Fatigued or broken spring washers.
Pressure spikes regulator vent hole	<ul style="list-style-type: none"> • Minimum by-pass of 5% not present. • Excessive pressure adjustment made for worn nozzle REPLACE NOZZLE. Reset system pressure.
Leakage from regulator vent hole	<ul style="list-style-type: none"> • O-ring around piston worn or piston retainer scored. Service with o-ring kit. • Piston Retainer scored. Service with O-ring kit. • Fatigued or broken spring washers.

PRESSURE READING

Approximate Pressure Reading at Gauge	Gauge Between Pump/Regulator	Gauge Between Regulator/Gun-Nozzle-Valve
System in operation (gun open)	System Pressure	System Pressure
System in by-pass (guns closed)	200 - 300 psi above system pressure	200 - 300 psi above system pressure

EXPLODED VIEW

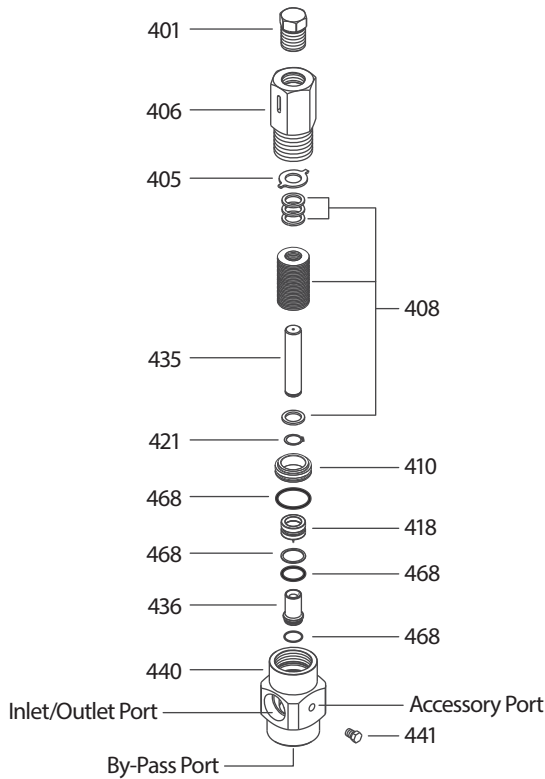

PARTS LIST

ITEM	DESCRIPTION	P/N	MATL	QTY
401	Nut, Adjusting	30666	BB R	1
405	Washer, Anti-Rotating	30719	STL	1
406	Body, Upper	—	STNP	1
408	Spring Set (22 spring washers, 4 flat washers)	76297	STL	1
410	Retainer, Piston	30665	SS	1
418	Piston, Conical	30730	SSB	1
421	Ring, Retainer	30714	STL R	1
435	Stem, Piston	30739	STL	1
436	Seat, Conical	30750	SSB	1
440	Body, Lower	—	SS	1
441	Plug, 1/4" NPT(M)	701077	SS	1
468	Kit, O-Ring	30725	FPM	1

Italics are optional items. R Components comply with RoHS Directive.
 Material Codes (Not Part of Part Number): BB=Brass FPM=Fluorocarbon
 SS=316SS SSB=316SS Condition B STNP=Steel/Nickel Plated STL=Steel
 It is recommended to replace spring washers and flat washers as a set.
 Contact Cat pumps for optional NBR or EPDM O-Ring Kits.

⚠ CAUTIONS AND WARNINGS

All High Pressure Systems require a primary pressure regulating device (i.e. regulator, unloader) and a secondary pressure relief device (i.e. pop-off valve, relief valve). Failure to install such relief devices could result in personal injury or damage to pump or property. Cat Pumps does not assume any liability or responsibility for the operation of a customer's high pressure system.

Read all CAUTIONS and WARNINGS before commencing service or operation of any high pressure system. The CAUTIONS and WARNINGS are included in each service manual and with each Accessory Data sheet. CAUTIONS and WARNINGS can also be viewed online at www.catpumps.com/cautions-warnings or can be requested directly from Cat Pumps.

WARRANTY

View the Limited Warranty on-line at www.catpumps.com/warranty.



CAT PUMPS

1681 - 94TH LANE N.E. MINNEAPOLIS, MN 55449-4324
 PHONE (763) 780-5440 — FAX (763) 780-2958
 e-mail: techsupport@catpumps.com
www.catpumps.com