

Stainless Steel Pressure Sensitive Regulator Unloader

Model **7501**

FEATURES

- Provides system pressure setting and protection for single gun (non-weep) and single pump installation.
- Remove check valve for regulator/relief valve operation.
- 316SS construction for compatibility and corrosion resistance.
- Compact size with optional ports for easy installation.
- Pressure sensitive feature permits wide range of flows and immediate pressure when gun opens.
- Adjusting cap permits easy adjustments of pressure.

SPECIFICATIONS

	U.S. Measure	Metric Measure
Flow Range	0.5-6.0 gpm	(1.9-23.0 lpm)
Pressure Range.....	100-2000 psi	(7-140 bar)
Maximum Operating Temperatures:		
Standard Buna O-Rings	180°F	(82°C)
Optional FPM O-Rings	240°F	(116°C)
Inlet Port (Back)	3/8" NPTM	(3/8" NPTM)
Outlet Port (Front).....	3/8" NPTM	(3/8" NPTM)
By-Pass Port (Bottom)	3/8" NPTF	(3/8" NPTF)
Weight.....	13.6 oz.	(0.38 kg)
Dimensions.....	3.03 x .94 x 4.23"	(77 x 24 x 107 mm)

For Relief Valve version add .100 to unloader model number.
For FPM version add .0110 to unloader model number.

⚠ CAUTIONS AND WARNINGS

All High Pressure Systems require a primary pressure regulating device (i.e. regulator, unloader) and a secondary pressure relief device (i.e. pop-off valve, relief valve). Failure to install such relief devices could result in personal injury or damage to pump or property. CAT PUMPS does not assume any liability or responsibility for the operation of a customer's high pressure system.

Read all CAUTIONS and WARNINGS before commencing service or operation of any high pressure system. The CAUTIONS and WARNINGS are included in each service manual and with each Accessory Data sheet. CAUTIONS and WARNINGS can also be viewed online at www.catpumps.com/cautions-warnings or can be requested directly from CAT PUMPS.

WARRANTY

View the Limited Warranty on-line at www.catpumps.com/warranty.

**Read all CAUTIONS and WARNINGS before commencing
service or operation of any high-pressure system**

SELECTION

These are pressure sensitive regulating unloaders, designed for systems with single or multiple pumps, solenoid (gate) valves, nozzles, standard or “weep” guns.

Note: For multiple pump systems, it is best to use a pressure regulator not a pressure sensitive regulating unloader.

These pressure sensitive regulating unloaders should meet both the desired system flow (combined nozzle flow rate requirement) and the desired system pressure.

Note: Operation below the minimum flow of the unloader causes the unloader to cycle. Operation above the maximum flow of the unloader causes premature unloader wear, cycling and prevents attaining desired system pressure.

INSTALLATION

These unloaders operate properly when mounted in any direction, however, it is preferred to keep the plumbing to a minimum and the hex adjusting cap easily accessible. The best mounting location is directly onto the pump discharge manifold head.

The inlet connection is a 3/8” NPTM sized port located on the back side of the unloader. An arrow is cast into the body indicating the direction of flow through the valve. Liquid from the discharge of the pump goes through this connection.

The discharge connection is a 3/8” NPTM sized port located on the front side (hex end). An arrow and the word OUT is cast into the body indicating the direction of flow. Plumbing for spray guns, solenoid (gate) valves or nozzles is connected here.

The by-pass connection is a 3/8” NPTF sized port located on the bottom. By-Pass liquid is directed out of this port and can be routed to a reservoir (preferred method), or to a drain or to the pump inlet.

OPERATION

These pressure sensitive regulating unloaders hold established system pressure in the discharge line when the trigger gun is closed or solenoid (gate) valve is closed or the nozzle is clogged, thus by-passing all unrequired flow. Squeezing the trigger gun or opening the solenoid (gate) valve will close off the by-pass and return to established system pressure without delay.

PRESSURE ADJUSTMENT

1. Setting and adjusting the unloader pressure must be done with the system “on”.
2. Start the system with unloader backed off to the lowest pressure setting (counterclockwise direction).
3. Squeeze the trigger and read the pressure on the gauge at the pump.

Note: Do not read the pressure at the gun or nozzle.

4. If more pressure is desired, release the trigger, turn hex adjusting cap one quarter turn in clockwise direction.
5. Squeeze the trigger and read the pressure.
6. Repeat this process until desired system pressure is attained.
7. Once the desired system pressure is reached, stop turning the hex adjusting cap.

Note: Pressure is not set at the factory.

Notice: A minimum by-pass flow of 5% of the unloader rated flow capacity is required for proper unloader performance. If the entire out is directed through the nozzle (zero by-pass) the “cushioning” feature of the by-pass liquid is eliminated and the unloader can malfunction or wear prematurely.

8. If desired system pressure cannot be reached, review TROUBLESHOOTING chart.
9. When servicing existing systems, follow adjustment procedures as stated above for new unloaders.

Note: Do not adjust unloader pressure setting to compensate for a worn nozzle. Check the nozzle as part of the regular maintenance and replace if worn.

Note: A secondary pressure relief device (i.e. pop-off valve) should be used along with this pressure sensitive regulating unloader. Final adjustment for the relief valve should relieve at 200 psi above the system operating pressure.

TYPICAL UNLOADER INSTALLATION

- 1 Pressure Gauge
- 2 Relief Valve
Shown as a secondary relief valve
- 3 Pulsation Dampener
- 4 Pressure Sensitive Regulating Unloader
- 5 Triplex Plunger Pump

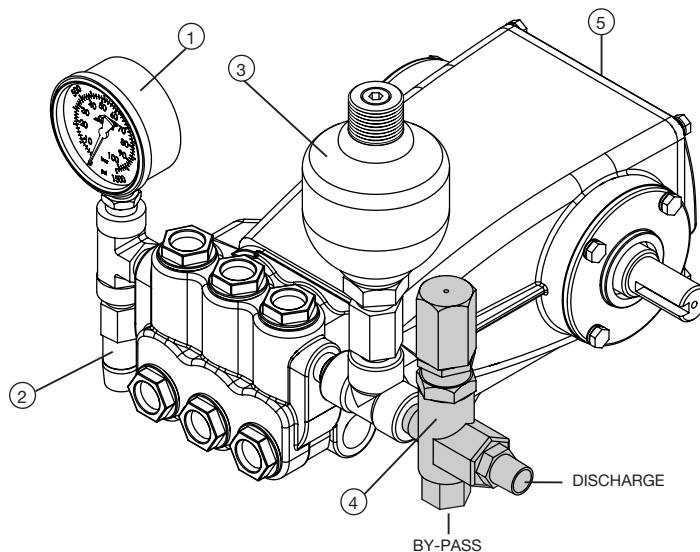

Read all CAUTIONS and WARNINGS before commencing service or operation of any high-pressure system

SERVICING

Disassembly:

1. Disconnect by-pass, discharge and inlet plumbing from unloader.
2. Remove unloader from pump.
3. Secure body of unloader in a vise with hex adjusting cap facing up.
4. Remove discharge fitting and o-ring, spring, check valve and o-ring.
5. Examine check valve and discharge fitting for wear, spring for wear or fatigue and o-rings for cuts or wear and replace as needed.

Note: While the discharge fitting is removed, inspect sealing area where the check valve makes contact within the internal body of the unloader for grooves, pitting and wear. If damage is found, stop the repair and replace with complete new unloader. If not, proceed with disassembly.

6. Remove hex adjusting cap by turning in a counterclockwise direction.
7. Remove spring and spring retainer.
8. Examine spring and spring retainer for scale build up, fatigue or wear and replace as needed.
9. Remove by-pass fitting with o-ring from bottom port.
10. Remove seat with o-ring from the male threaded side of by-pass fitting.
11. Examine seat for scale build up, scoring and wear and replace as needed. Examine o-ring for cuts or wear and replace as needed.
12. Removal of piston stem and valve/ball assembly requires the use of a small hex socket and screwdriver. Insert screwdriver from the top and place in slotted head of piston stem. Insert small hex socket into bottom port and secure valve/ball assembly. Unthread by turning in a counterclockwise direction.
13. Examine piston stem and valve/ball assembly for scale build up, scoring, pitting and wear and replace as needed. Examine o-rings and backup ring for cuts or wear and replace as needed.
14. Remove piston retainer with o-rings and backup rings by turning in a counterclockwise direction.
15. Examine piston retainer for wear. Examine o-rings and back-up-ring for cuts or wear and replace as needed.

Reassembly:

1. Lubricate and install small body back-up-ring and then body o-ring into unloader body.
2. Lubricate and install o-ring over threads of piston retainer.
3. Carefully hand thread piston retainer with small diameter hole facing down into unloader body and tighten with a wrench.
4. Lubricate and install o-ring over piston stem head and then backup-ring into groove of piston stem.
5. Apply Loctite® 242® to the last few threads of the piston stem.
6. Insert piston stem from the top through the piston retainer until seated.
7. Using the same tools in removing the piston stem and valve/ball assembly, place valve/ball assembly into hex socket tool with ball surface facing down into socket. Place screwdriver tip into piston stem slotted head. Thread piston stem into valve/ball assembly.
8. Place by-pass fitting on flat surface with male threads facing up.
9. Lubricate and install o-ring onto seat. Press seat into by-pass fitting. Hand thread by-pass fitting into lower port of unloader body and tighten with wrench.
10. Lubricate and install o-ring on discharge fitting.
11. Insert spring into discharge filling, then insert check valve with small step end into spring. Hand thread into unloader body and tighten with wrench.
12. Place spring retainer on top of piston stem.
13. Place spring on to spring retainer.
14. Thread hex adjusting cap onto piston retainer.
15. Remove unloader from vise.
16. Re-install unloader onto pump.
17. Reconnect by-pass, discharge and inlet plumbing to unloader.
18. Proceed to PRESSURE ADJUSTMENT.

Loctite® and 242® are registered trademarks of the Henkel Corporation.

TROUBLESHOOTING

Unloader cycles	<ul style="list-style-type: none"> ● Check for leak downstream of unloader. ● Worn O-ring or check valve. ● Air in system, poor connection. ● O-ring in gun worn. ● Insufficient flow through unloader.
Liquid leaking from bottom fitting	<ul style="list-style-type: none"> ● O-ring for fitting cut or worn. ● O-ring for seat cut or worn.
Liquid leaking from middle	<ul style="list-style-type: none"> ● O-ring for piston worn or cut. ● O-rings for piston stem worn or cut.
Unloader will not come up to pressure	<ul style="list-style-type: none"> ● Not properly sized for system pressure. ● Foreign material in unloader. Clean filter. ● Piston stem O-rings worn. ● Nozzle worn. ● Insufficient flow to pump.
Extreme pressure spikes	<ul style="list-style-type: none"> ● Adjusting nut turned completely into unloader. ● Restricted by-pass or no by-pass. ● System flow exceeds unloader rating.
Filtration	<ul style="list-style-type: none"> ● Clean filter on regular schedule to avoid cavitation.

PRESSURE READING

Approximate Pressure Reading at Gauge	Gauge Between Pump/Unloader	Gauge Between Unloader/Gun-Nozzle-Valve
System in operation (gun open)	system pressure	system pressure
System in by-pass (all guns, valves closed)	low pressure 0-150 PSI	system pressure +200 PSI

EXPLODED VIEW

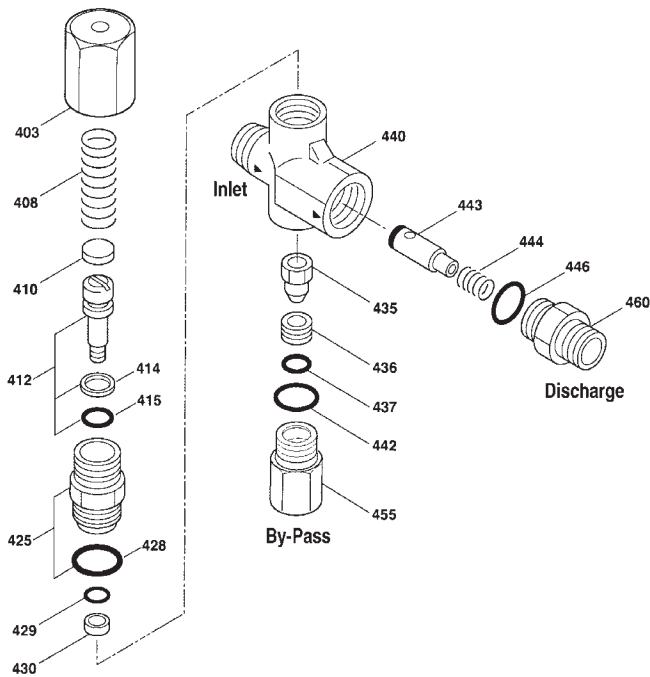

CUTAWAY

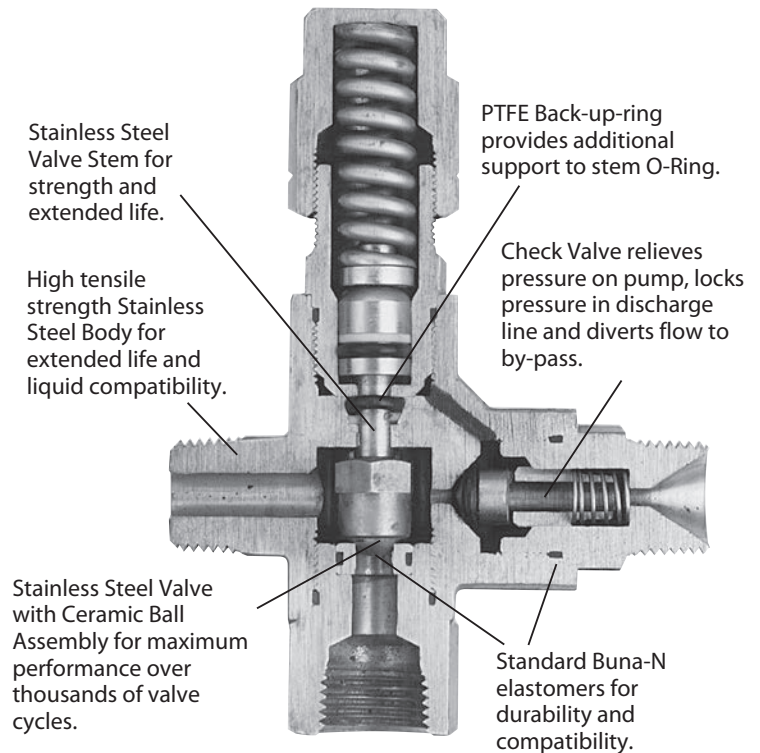

PARTS LIST

ITEM	PN	MATL	DESCRIPTION	QTY
403	546144	SS	Cap, Hex Adjusting	1
408	32094	STZP R	Spring, Pressure	1
410	546146	SS	Retainer, Spring	1
412	546149	SS	Stem, Piston w/Back-up-Ring and O-Ring	1
414	20184	PTFE	Back-up-Ring, Piston Stem	1
415	14190	NBR	O-Ring, Piston Stem - 70D	1
	14161	FPM	O-Ring, Piston Stem - 70D	7
425	546147	SS	Retainer, Piston w/O-Ring	1
428	13969	NBR	O-Ring, Piston Retainer - 70D	1
	14320	FPM	O-Ring, Piston Retainer - 70D	7
429	14759	NBR	O-Ring, Stem	1
	14160	FPM	O-Ring, Stem - 80D	7
430	107675	PTFE	Back-up-Ring, Piston Stem	1
435	546151	S SCC	Valve/Ball Assembly	1
436	546154	SS	Seat	1
437	13963	NBR	O-Ring, Seat - 70D	1
	14303	FPM	O-Ring, Seat - 70D	7
440	—	SS	Body	1
442	13969	NBR	O-Ring, By-Pass Fitting - 70D	1
	14320	FPM	O-Ring, By-Pass Fitting - 70D	7
443	546158	SS	Valve, Check w/O-Ring - 90D	1
444	546160	SS	Spring, Check Valve	1
446	13969	NBR	O-Ring, Discharge Fitting - 70D	1
	14320	FPM	O-Ring, Discharge Fitting - 70D	7
455	546976	SS	Fitting, By-Pass (3/8" NPTF)	1
460	546979	SS	Fitting, Discharge (3/8" NPTM)	1
468	32097	NBR	Kit, O-Ring (Incls: 414, 415, 428, 429, 430, 437, 442, 446)	1
	31627	FPM	Kit, O-Ring (Incls: 414, 415, 428, 429, 430, 437, 442, 446)	7

Italics are optional items. R Components comply with RoHS Directive.
 MATERIAL CODES (Not Part of Part Number): FPM=Fluorocarbon NBR=Medium Nitrile (Buna-N)
 PTFE=Pure Polytetrafluoroethylene SS=316SS S SCC=316SS/Ceramic STZP=Steel/Zinc Plated



CAT PUMPS

1681 - 94TH LANE N.E. MINNEAPOLIS, MN 55449-4324
 PHONE (763) 780-5440 — FAX (763) 780-2958
 e-mail: techsupport@catpumps.com
 www.catpumps.com