



FEATURES

- Impeller:** Polyurethane for wear and corrosion resistance.
- Adjustable Discharge:** Discharge can be installed for either vertical or horizontal installation using only 2 screws.
- Diffuser:** Polyurethane for wear and corrosion resistance.
- Mechanical Seal:** Dual seals for double leakage protection, outer seal - silicon carbide.
- Rubber Liner:** Protects against wear around impeller.
- Bottom Strainer:** Made of impact absorbing EPDM rubber, suction holes allow for low pump down.

2DW

SUBMERSIBLE DEWATERING PUMP



APPLICATIONS

Specifically designed to remove water from:

- Drainage ditches
- Trenches
- Basements
- Manholes
- Excavating drainage in the building trades

SPECIFICATIONS

Pump:

- Discharge size: 2" NPSM threaded hose coupling design, can be rotated
- Capacities: up to 84 GPM
- Total heads: up to 51 feet
- Maximum solids: any particles passing through strainer
- Mechanical seals: outer seal - silicon carbide, inner seal - carbon ceramic

- Temperature limit: 95°F (35° C) maximum
- Depth of immersion: 16.5 feet (5m) maximum

Motor:

- Single phase: 3500 RPM, ½ HP and 1 HP, 115 and 230 V, 60 Hz
- Built-in starter with full overload and temperature protection.
- Class F insulation.
- Air filled design.
- Upper and lower heavy duty ball bearing construction.
- Power cord: 50 feet.

AGENCY LISTINGS



Tested to UL778 and CSA 22.2 108 standards by Canadian Standards Association.
NRTL File #LR13533

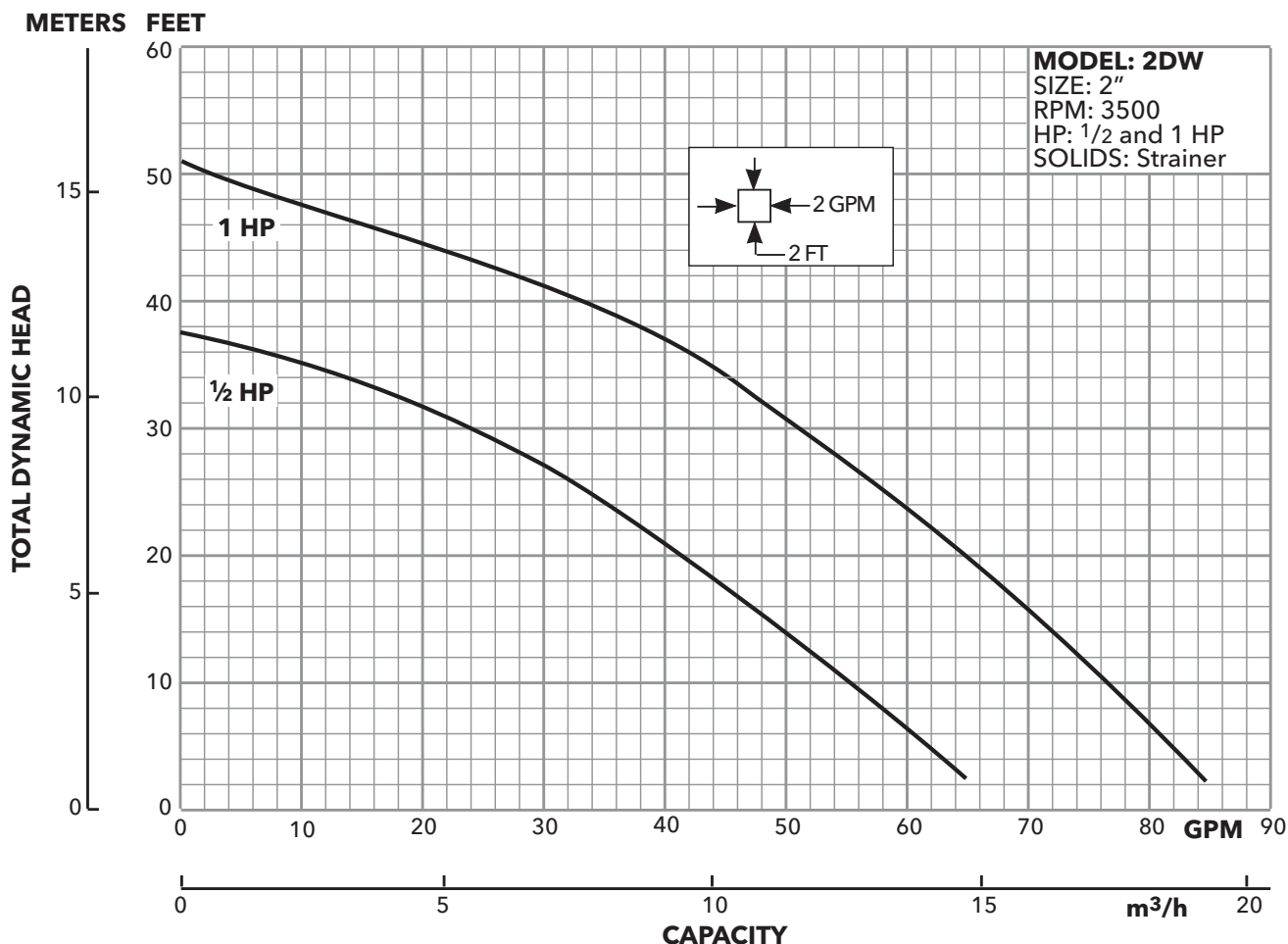

REPLACEMENT KITS

Each kit contains the following parts:

Impeller Kit (15K97 for ½ HP, 15K98 for 1 HP) - Impeller, impeller screw, protective plug, washer, assembly instruction

Diffuser Kit (15K99 for both ½ HP and 1 HP) - Diffuser, barrel nuts, screws, washers, assembly instruction, sticker

Outer seal Kit (15K14 for both ½ HP and 1 HP) - Mechanical face-seal unit, assembly instruction, sticker

O-ring Kit (15K100 for both ½ HP and 1 HP) - All o-rings

MODEL INFORMATION

Order No.	HP	Volts	Phase	Maximum Amp	RPM	Height (in.)	Weight (lbs.)
2DW0511	½	115	1	5.5	3500	17.25	26
2DW0512		230		2.9			
2DW1011	1	115		9.8			
2DW1012		230		4.9			32

DIMENSIONS

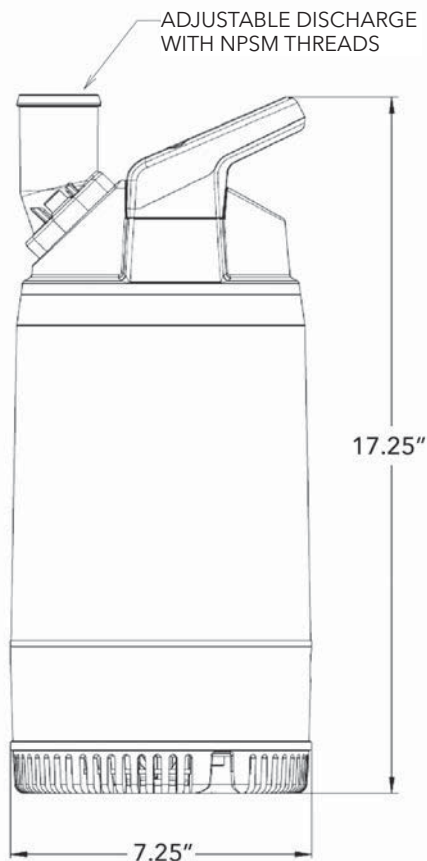

COMPONENTS

Item No.	Description	
1	Discharge	Not Available
2	Power cord	Not Available
3	Handle/cover	Not Available
4	Support bearing	Not Available
5	Pump casing	Not Available
6	Main bearing	Not Available
7	Inner mechanical seal	Not Available
8	Outer mechanical seal	Available
9	Impeller	Available
10	Suction cover/diffuser	Available
11	Strainer	Not Available
12	Oil plug	Not Available
13, 14	Motor	Not Available

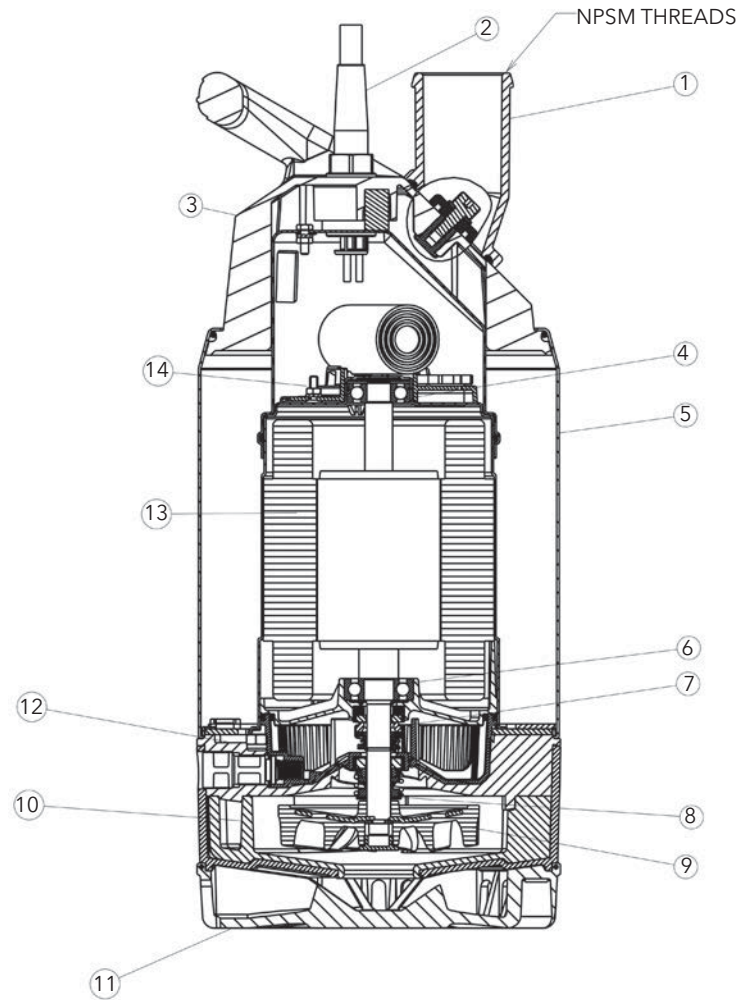

xylem
Let's Solve Water

Xylem Inc.
2881 East Bayard Street Ext., Suite A
Seneca Falls, NY 13148
Phone: (866) 325-4210
Fax: (888) 322-5877
www.gouldswatertechnology.com

Goulds is a registered trademark of Goulds Pumps, Inc. and is used under license.
© 2016 Xylem Inc. B2DW R4 September 2016