



# WS\_B Series

## Model 3886Z 50 Hz

SUBMERSIBLE SEWAGE PUMPS



### FEATURES

Impeller: Cast iron, semi-open, dynamically balanced, non-clog with pump out vanes for mechanical seal protection. Optional Silicon bronze impeller available.

Casing: Cast iron volute type for maximum efficiency. Designed for easy installation on A10-20 slide rail.

Mechanical Seal: SILICON CARBIDE VS. SILICON CARBIDE sealing faces for superior abrasive resistance, stainless steel metal parts, BUNA-N elastomers.

Shaft: Corrosion-resistant stainless steel. Threaded design. Locknut on three phase models to guard against component damage on accidental reverse rotation.

Fasteners: 300 series stainless steel.

Capable of running dry without damage to components.

Designed for continuous operation, when fully submerged.

### APPLICATIONS

Specifically designed for the following uses:

- Homes
- Sewage systems
- Dewatering/Effluent
- Water transfer

### SPECIFICATIONS

#### Pump:

- Solids handling capabilities: 2" maximum
- Discharge size: 2" NPT (STD.)
- 2" BSPP (optional)
- Capacities: up to 160 GPM
- Total heads: up to 26 feet TDH
- Temperature:
  - 104°F (40°C) continuous
  - 140°F (60°C) intermittent.
- See order numbers on reverse side for specific HP, voltage, phase and RPM's available.

### MOTORS

- Fully submerged in high grade turbine oil for lubrication and efficient heat transfer. All ratings are within the working limits of the motor.

- Class B insulation

Single phase (50 Hz):

- All single phase models feature capacitor start motors for maximum starting torque.
- Built-in overload with automatic reset.
- 1/3 and 1/2 HP - 16/3 SJTOW with bare leads.
- 3/4 - 14/3 STOW with bare leads.

Three phase (50 Hz):

- Overload protection must be provided in starter unit.
- 1/3- 3/4 HP - 14/4 STOW with bare leads.
- Bearings: Upper and lower heavy duty ball bearing construction.
- Designed for Continuous Operation: Pump ratings are within the motor manufacturer's recommended working limits, can be operated continuously without damage.
- Power Cable: Severe duty rated, oil and water resistant. Epoxy seal on motor end provides secondary moisture barrier in case of outer jacket damage and to prevent oil wicking. 20 foot standard with optional lengths available.
- Motor Cover O-ring: Assures positive sealing against contaminants and oil leakage.

### MODELS

Order Number	HP	Volts	Phase	RPM	Impeller Diameter	Maximum Amps	Weight (lbs.)
WS0329B	1/3	220	1	1450	5"	7.2	63
WS0346B		380	3			1.3	
WS0529B	1/2	220	1		5 3/8"	7.8	65
WS0546B		380	3			1.5	
WS0729B	3/4	220	1		5 3/4"	8.6	70
WS0746B		380	3			2.3	

Complete System Components available in the accessory section of this catalog.

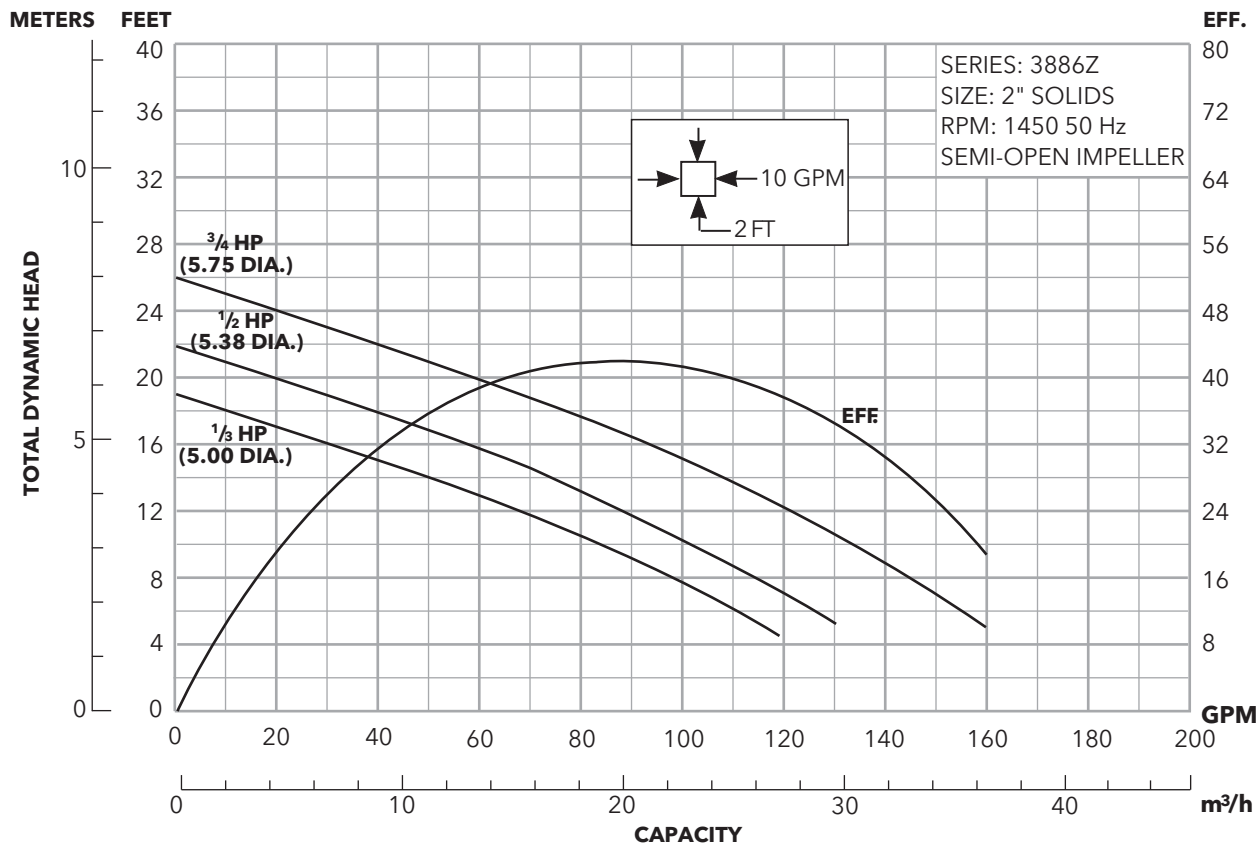

## DIMENSIONS

(All dimensions are in inches. Do not use for construction purposes.)

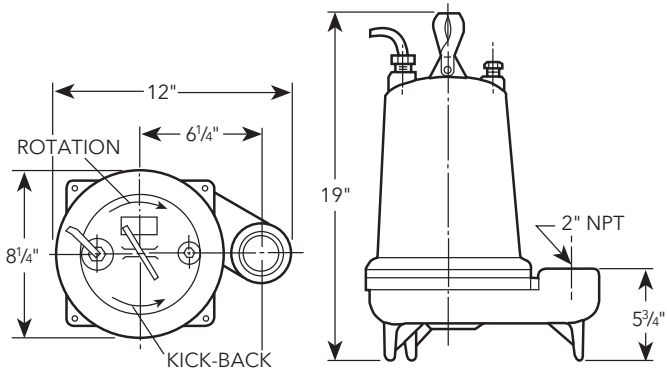

## COMPONENTS FOR REFERENCE ONLY

Item No.	Description
1	Impeller
2	Casing
3	Silicon carbide vs. silicon carbide Mechanical seal
4	Shaft
5	Motor
6	Ball bearings
7	Power cable
8	O-ring

**NOTE:** Repair parts may be ordered from repair parts list.

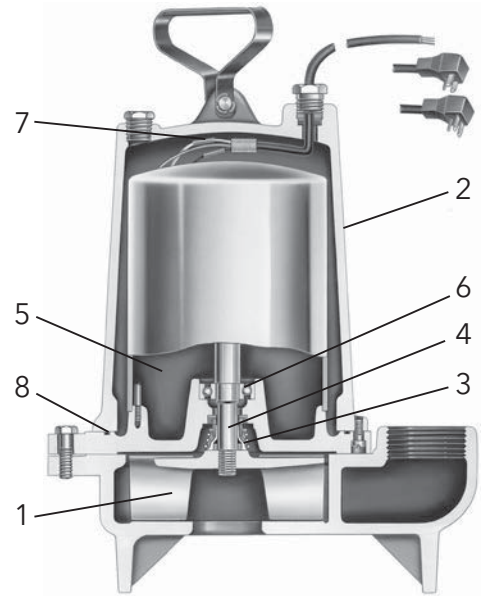

**xylem**  
Let's Solve Water

Xylem Inc.  
2881 East Bayard Street Ext., Suite A  
Seneca Falls, NY 13148  
Phone: (866) 325-4210  
Fax: (888) 322-5877  
[www.gouldswatertechnology.com](http://www.gouldswatertechnology.com)

Goulds is a registered trademark of Goulds Pumps, Inc. and is used under license.  
© 2016 Xylem Inc. B3886Z R1 September 2016