

**FEATURES**

Impeller: Cast iron, ASTM A48, Class 30, two vane semi-open, non-clog design with pump out vanes for mechanical seal protection. Balanced for smooth operation. Silicon bronze impeller is an option.

Casing: Heavy duty gray cast iron, ASTM A48, Class 30. Volute type casing with 3", 125#, ANSI flanged, horizontal discharge. Compatible with A10-30 cast iron or A10-30B cast iron and brass (non-sparking) guide rail assembly.

Dual Mechanical Seals: Silicon carbide vs. silicon carbide outer seal and ceramic vs. carbon inner seal, stainless steel metal parts, BUNA-N elastomers. Upper and lower shaft seals are positioned independently and are separated by an oil-filled chamber.

Shaft: 300 series stainless steel keyed design.

Fasteners: 300 series stainless steel.

Capable of running dry temporarily without damage to seals or motor.

WS_D3 Series

Model 3888ZD3 50 Hz

SUBMERSIBLE SEWAGE PUMPS

50 Hz Wastewater

APPLICATIONS

Used in a variety of residential, commercial and industrial applications such as:

- Sewage systems, Flood and Pollution Control, Dewatering/Effluent, Farms, Hospitals, Trailer Courts, Motels

SPECIFICATIONS

Pump:

- Maximum solid size: 2.5"
- Discharge size: 3", 125 # ANSI flange
- Maximum capacity: 440 GPM
- Maximum total head: 45 feet
- 300 Series stainless steel fasteners
- 20' Power cord
- Standard silicon carbide/silicon carbide outer seal

Motor:

- Maximum ambient temperature: 104° F (40° C) continuous duty, 140° F (60° C) intermittent duty
- Rated for continuous duty when fully submerged
- Insulation: Class F
- 50 Hertz
- Single row ball bearings
- 300 Series stainless steel keyed shaft

Single Phase:

- 1.5 - 3 HP; 220 volts
- Built-in thermal overloads with automatic reset
- Built-in capacitors

Three Phase:

- 1.5 - 3 HP; 200, 380 volts
- Class 10 overload protection must be provided in control panel

MOTORS

- Fully submerged in oil-filled chamber. High grade turbine oil surrounds motor for more efficient heat dissipation, permanent lubrication of bearings and mechanical seal for complete protection against outside environment.
- Class F insulation
- Designed for Continuous Operation: Pump ratings are within the motor manufacturer's recommended working limits and can be operated continuously without damage when fully submerged.
- Bearings: Upper and lower heavy duty ball bearing construction for precision positioning of parts and to carry thrust loads.
- Power Cable: Severe duty rated, oil and water resistant. Epoxy seal on motor end provides secondary moisture barrier in case of outer jacket damage and to prevent oil wicking. 20 foot standard with optional lengths available.
- O-ring: Assures positive sealing against contaminants and oil leakage.

AGENCY LISTINGS



Tested to UL 778 and CSA 22.2 108 Standards
By Canadian Standards Association File #LR38549

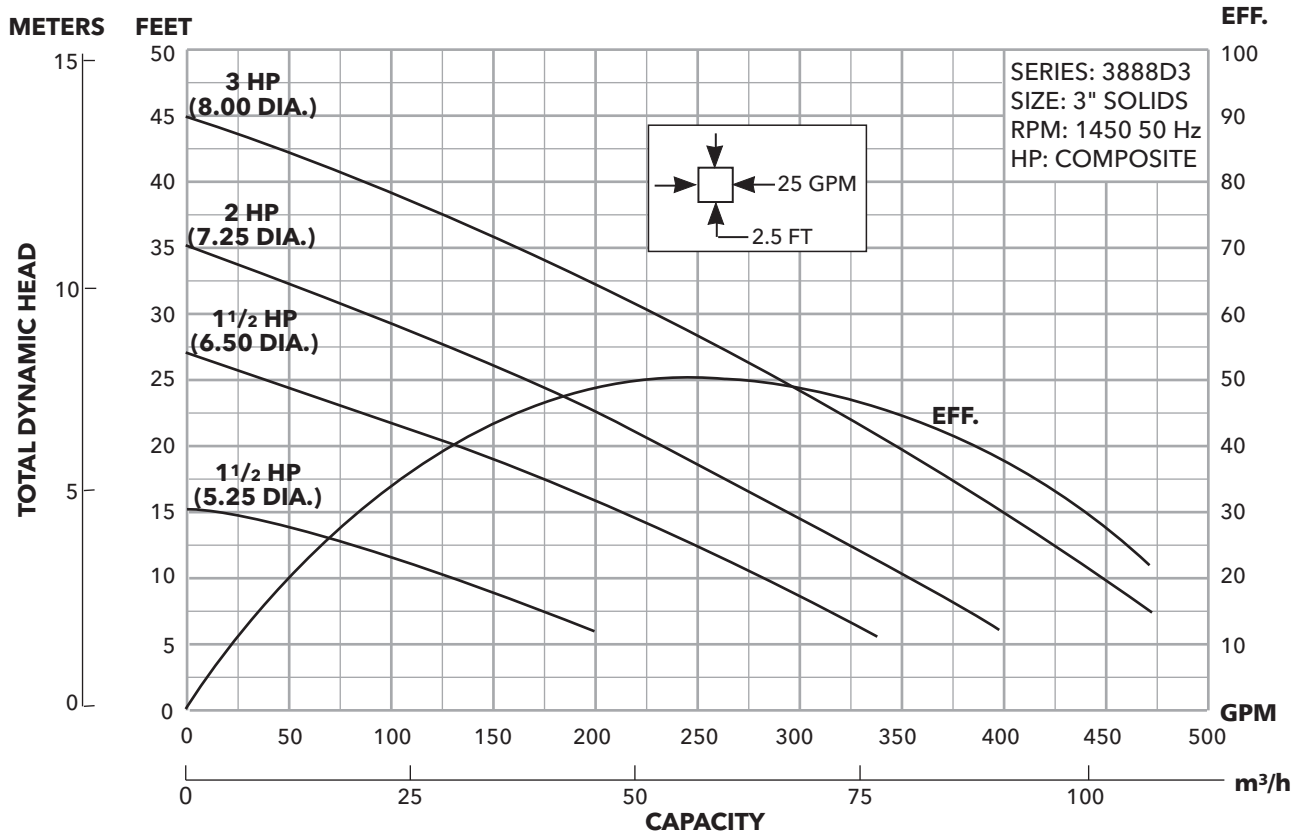

SEWAGE PUMP 50 HZ: 3" FLANGED DISCHARGE, 2.5" SOLIDS MODEL AND MOTOR INFORMATION

Order No.	HP	Phase	Volts	RPM	Impeller Dia. (in.)	Maximum Amps	L.R. Amps	KVA Code	Power Cable	F.L. Motor Eff. %	Resistance		Wt. (lbs.)
											Start	Line-Line	
WS1529D3M	1.5	1	220	1450	5.25"	5.8	32.7	D	14/3	80	2.1	1.2	192
WS1546D3M		3	380			2.6	24.2	F	14/4	83	N/A	9.3	190
WS1548D3M		3	200			5.2	48.4	F	14/4	83	N/A	2.3	190
WS1529D3	1.5	1	220		6.5"	8.9	32.7	D	14/3	80	2.1	1.2	192
WS1546D3		3	380			3.8	24.2	F	14/4	83	N/A	9.3	190
WS1548D3		3	200			7.6	48.4	F	14/4	83	N/A	2.3	190
WS2029D3	2	1	220		7.25"	11.9	32.7	D	14/3	80	2.1	1.2	196
WS2046D3		3	380			4.9	24.2	F	14/4	83	N/A	9.3	194
WS3029D3	3	1	220		8.0"	18.6	52.1	A	10/3	80	1.3	0.9	205
WS3046D3		3	380	7.2		30.0	H	14/4	83	N/A	7.5	200	
WS3048D3		3	200	14.4		60.0	H	14/4	83	N/A	1.9	200	

DIMENSIONS

(All dimensions are in inches. Do not use for construction purposes.)

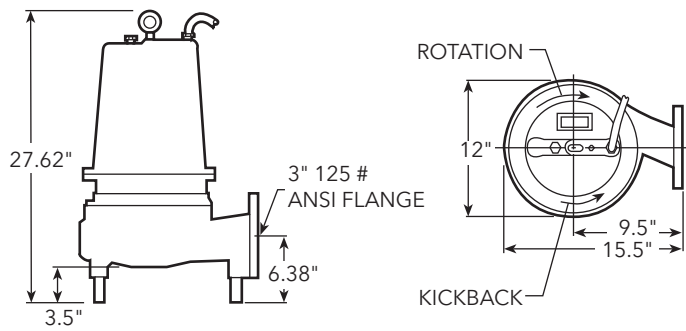

MATERIALS OF CONSTRUCTION

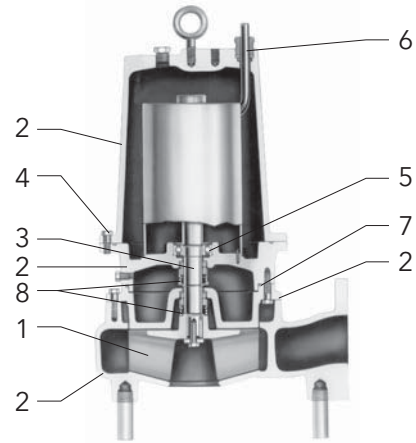

Item No.	Part Name		Material			
			Standard		Optional	
1	Impeller, non-clog		1003		1179	
2	Castings		1003			
3	Shaft-keyed		300 Series SS			
4	Fasteners		300 Series SS			
5	Ball bearings		Steel			
6	Power cable		STOW, 20 feet		Additional lengths	
7	O-ring		BUNA-N			
8	Outer Mech. Seal	Service	Rotary	Stationary	Elastomers	Metal Parts
	OPT	Heavy duty	Silicon Carbide	Tungsten Carbide	BUNA-N	300 Series SS
	STD	Mild abrasives	Silicon carbide		BUNA-N	300 Series SS
Material Code			Engineering Standard			
1003			Cast iron – ASTM A48 Class 30			
1179			Silicon bronze – ASTM C87600			

APPLICATION DATA AND CONSTRUCTION DETAILS

Maximum Solid Size	2.5"	
Minimum Casing Thickness	5/16"	
Casing Corrosion Allowance	1/8"	
Maximum Working Pressure	30 PSI	
Maximum Submergence	50 feet	
Minimum Submergence	Fully submerged for continuous operation	
	6" below top of motor for intermittent operation	
Maximum Environmental Temperature	40° C (104° F) continuous operation, 60° C (140° F) intermittent operation	
Power Cable - Type (See Motor Information for AWG data/size.)	Type SJTOW: single phase, 1½ and 2 HP	
	Type STOW: single phase, 1½ - 3 HP and 5 HP, 380 V	
	Type STOW: single phase, 3 HP, three phase 5 HP, 200 V	
Motor Cover, Bearing Housing, Seal Housing, Casing	Gray Cast Iron - ASTM A48, Class 30	
Impeller - Standard, Optional	Gray Cast Iron - ASTM A48 or Cast Bronze - ASTM B584 C87600	
Motor Shaft	AISI 300 Series Stainless Steel	
Motor Design	NEMA 56 Frame, oil filled with Class F Insulation	
Motor Overload Protection	Single phase: on winding thermal overload protection auto reset	
	Three phase: requires Class 10 overloads in control panel	
External Hardware	300 Series Stainless Steel	
Impeller Type	Semi-open with pump out vanes on back shroud	
Oil Capacity - Seal Chamber	1.5 quarts	
Oil Capacity - Motor Chamber	1½-5 HP single and three phase: 7 quarts	
Mechanical Seals - Standard	Upper	Carbon/Ceramic; Type 21
	Lower	Silicon Carbide/Silicon Carbide; Type 31
Mechanical Seals - Optional Lower	Silicon Carbide/Tungsten Carbide; Type 31	



Xylem, Inc.
 2881 East Bayard Street Ext., Suite A
 Seneca Falls, NY 13148
 Phone: (866) 325-4210
 Fax: (888) 322-5877
www.xylem.com/brands/gouldswatertechnology

Goulds is a registered trademark of Goulds Pumps, Inc. and is used under license.
 © 2012 Xylem Inc. B3888ZD3 March 2011