

**FEATURES**

**Impeller:** Cast iron multi-vane vortex style, with rip vane on the back edge of the impeller for removing stringy solids.

**V model designation** for vortex impeller

**Casing:** Cast Iron construction with large unobstructed passage way to pass large solids.

Efficient air-filled motor

**Stand:** Optional stand for mounting without slide rail configuration. Part number: 7482200

**Dual Mechanical Seals:**

**Up to 5 HP:**

For standard pumps, Tungsten Carbide vs. Ceramic seal faces standard on outer seals.

Carbon vs. Ceramic standard on inner seals.

**Over 5 HP:**

Tungsten Carbide vs. Tungsten Carbide faces standard on outer seals. Tungsten

Carbide vs. Carbon standard on inner seals.

All elastomers shall be nitrile.

**For All Explosion Proof:**

Tungsten Carbide vs. Ceramic faces standard on outer and inner seals. < 5 HP use viton elastomers, > 5 HP use nitrile.

**Seal Sensor / High Temperature Probe:** Located in motor housing. If pumpage should begin to leak past lower seal it indicates to pump control panel a fault has occurred.

**Requires MiniCAS device in the control panel.**

Capable of running dry without damage to components.

Designed for continuous operation, when fully submerged.

Explosion-proof available as option. FM approved.

**Shaft:** Corrosion resistant, 400 series stainless steel. Taper lock and impeller bolt on all models to guard against component damage on accidental reverse rotation.

**Fasteners:** 300 series stainless steel.

Grease for life bearings



# 4GV Plus

SUBMERSIBLE 4" SEWAGE PUMP - DUAL SEAL WITH SEAL SENSOR PROBE

### APPLICATIONS

Specifically designed for the following uses:

- Sewage systems
- Dewatering/Effluent
- Water transfer
- Light industrial
- Commercial applications

Anywhere waste or drainage must be disposed of quickly, quietly and efficiently.

### SPECIFICATIONS

#### Pump:

- Maximum soft solid size: 3"
- Capacities: up to 1200 GPM
- Total heads: up to 80' TDH
- Discharge size: 4" ANSI Flange

#### Motor:

- Maximum ambient temperature: 104° F (40° C) continuous duty
- Rated for continuous duty when fully submerged
- Insulation: Class H
- 60 Hertz
- Single row ball bearings
- 400 Series stainless steel taper lock shaft
- Requires overload protection in panel (not included)
- Includes high temperature sensor for winding protection

### AIR-FILLED MOTOR

- Efficient heat dissipation
- Run dry capability
- Class H insulation
- Designed for Continuous Operation: Pump ratings are within the motor manufacturer's recommended working limits and can be operated continuously without damage when fully submerged.
- Bearings: Upper and lower heavy duty ball bearing construction for precision positioning of parts and to carry thrust loads.
- High temperature winding protection
- Cord: Severe duty rated, oil and water resistant. 30 foot standard.
- O-ring: Assures positive sealing against contaminants and oil leakage.

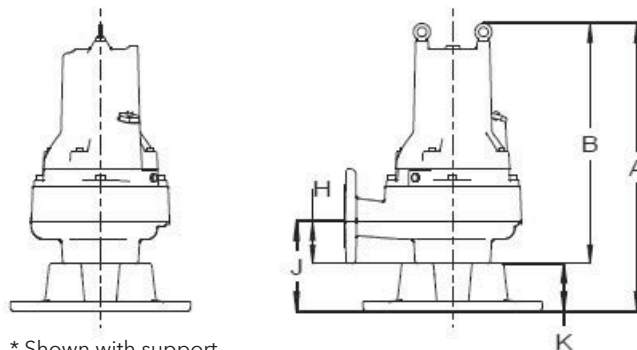

\* Shown with support kit (sold separately).

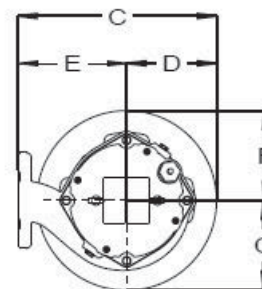

### DIMENSIONS

Model No.	A	B	C	D	E	F	G	H	J	K
4GV A, B, C, D Impeller	30.47" [774]	26.54" [674]	17.13" [435]	7.48" [190]	9.65" [245]	7.48" [190]	7.48" [190]	4.84" [123]	8.78" [223]	3.94" [100]
4GV F, G, H Impeller	26.50" [673]	22.56" [573]	16.34" [415]	7.48" [190]	8.86" [225]	7.48" [190]	7.48" [190]	4.72" [120]	8.66" [220]	3.94" [100]

Stand Optional, Part no. 15K80

### MODEL AND MOTOR INFORMATION

Model No.	HP	Volts	Phase/Hz	Rated Current (Amps)	RPM	Impeller Diameter In (mm)	Insulation Class	Run Capacitor (mfd/ volt)	Start Capacitor (mfd/ volt)	Resistance (Ohms)	Aux. Resistance (Ohms)	Start Current (LR Amps)	Rated Motor kVA [Code]	Rated Motor Eff. (%)	Rated Power Factor (cos phi)	Starting Torque (NM)	Max. Torque (NM)	Pump Weight (lbs.)	Cable Size with water detector and thermostats																
4GV1022AD	10.0 (7.5 Kw)	200	3 / 60	31.0	1750	"A" 7.95" (202 mm)	H	N/A	N/A	0.505	N/A	157	5.4 [F]	85.1	0.83	60.0	98.3	270	10AWG / 3-2-1-GC																
4GV1023AD		230		27.0						0.500		136		84.7	0.82	58.0	97.4																		
4GV1024AD		460		14.0						2.000		68		84.7	0.82	58.0	97.4																		
4GV1025AD		575		11.0						4.230		56		5.5 [F]	84.9	0.82	61.0			99.7															
4GV7522BD	7.5 (5.6 Kw)	200		23.5		0.505				157		"B" 7.28" (185 mm)	H	N/A	N/A	0.505	N/A			157	5.4 [F]	85.1	0.83	60.0	98.3	270	10AWG / 3-2-1-GC								
4GV7523BD		230		21.2		0.500				136						84.7				0.82		58.0	97.4												
4GV7524BD		460		10.6		2.000				68						84.7				0.82		58.0	97.4												
4GV7525BD		575		8.3		4.230				56						5.5 [F]				84.9		0.82	61.0	99.7											
4GV6022CD	6.0 (4.5 Kw)	200		19.0		0.505				157		"C" 6.69" (170 mm)				H		N/A	N/A	0.505	N/A	157	5.4 [F]	85.1	0.83			60.0	98.3	270	10AWG / 3-2-1-GC				
4GV6023CD		230		17.2		0.500				136										84.7		0.82		58.0	97.4										
4GV6024CD		460		8.6		2.000				68										84.7		0.82		58.0	97.4										
4GV6025CD		575		6.8		4.230				56										5.5 [F]		84.9		0.82	61.0			99.7							
4GV5022FD	5.0 (3.7 Kw)	200		16.0		1.430				83		"F" 6.89" (175 mm)								H		N/A	N/A	1.430	N/A	83	5.8 [G]	80.3	0.82			42.0	51.6	160	14AWG / 7
4GV5023FD		230		14.0		1.300				67														5.4 [F]		80.2	0.85	38.0	47.9						
4GV5024FD		460		6.8		5.200				34														5.5 [F]		80.2	0.85	38.0	47.9						
4GV5025FD		575		5.8		11.900				30														6.0 [G]		79.8	0.81	42.0	52.4						
4GV4022GD	4.0 (3.0 Kw)	200	14.8	1.430	83	"G" 6.30" (160 mm)	H	N/A	N/A	1.430	N/A	83												5.8 [G]		80.3	0.82	42.0	51.6	160	14AWG / 7				
4GV4023GD		230	12.6	1.300	67					5.4 [F]		80.2												0.85		38.0	47.9								
4GV4024GD		460	6.3	5.200	34					5.5 [F]		80.2												0.85		38.0	47.9								
4GV4025GD		575	5.4	11.900	30					6.0 [G]		79.8												0.81		42.0	52.4								
4GV3122HD	3.1 (2.3 Kw)	200	13.2	1.430	83	"H" 5.79" (147 mm)				H		N/A	N/A	1.430	N/A		83							5.8 [G]		80.3	0.82	42.0	51.6			160	14AWG / 7		
4GV3123HD		230	11.2	1.300	67									5.4 [F]			80.2							0.85		38.0	47.9								
4GV3124HD		460	5.6	5.200	34									5.5 [F]			80.2							0.85		38.0	47.9								
4GV3125HD		575	4.8	11.900	30									6.0 [G]			79.8							0.81		42.0	52.4								

## APPLICATION DATA

Maximum Working Pressure	75 PSI (5 bar) - Standard
	150 PSI (10 bar) - Explosion Proof
Maximum Submergence	66 feet (20 m)
Minimum Submergence	Fully submerged for continuous operation
Maximum Environmental Temperature	40°C (104°F) continuous operation

## CONSTRUCTION DETAILS

Power / Sensor Cable	10/3-2-1 GC, type: three phase - 5.1 HP and up
	10/3-2-1 GC, type: three phase - 5.0 HP and less
Motor Cover	Gray Cast Iron - ASTM A48 Class 30
Seal / Bearing Housing	Gray Cast Iron - ASTM A48 Class 30
Casing	Gray Cast Iron - ASTM A48 Class 30
Impeller	Cast Iron
Motor Shaft	AISI 400 Series Stainless Steel
Motor Design	Air filled Class H
Motor Overload Protection	Three Phase: require ambient compensated Class 10, quick trip overloads in the control panel.
Motor Seal Fail / High Temp. Detection	Seal fail sensor and high temp. in an oil-filled seal chamber. Connect to optional relays in control panel.
External Hardware	300 Series Stainless steel
Impeller Type	Vortex with pump out vanes on back shroud
Oil Capacity - Seal Chamber	33.8 ounces

## MATERIALS OF CONSTRUCTION

Item No.	Part Name	Material			
		Standard			
1	Impeller	Cast Iron			
2	Motor Cover	Cast Iron			
3	Shaft	400 SS			
4	Fasteners	300 SS			
5	Ball Bearings	Steel			
6	Power Cable	SOW, 30 feet			
7	O-Ring	BUNA-N			
8	<b>Service</b>	<b>Rotary</b>	<b>Stationary</b>	<b>Elastomers</b>	<b>Metal Parts</b>
	Upper	Carbon / Ceramic		Nitrile	300 Series SS
	Outer	Tungsten Carbide / Ceramic			

## NOMENCLATURE DESCRIPTION

### 1st Character - Discharge Size

4 = 4" discharge

### 2nd and 3rd Characters - Series/Solids Size

GV = Vortex

### 4th Character - HP

31 = 3.1 HP

40 = 4.0 HP

50 = 5.0 HP

51 = 5.1 HP

60 = 6.0 HP

75 = 7.5 HP

10 = 10.0 HP

### 5th Character - Mechanical Seals

2 = 60 Hz/1750 RPM

### 6th Character - Phase/Voltage

2 = three phase, 200 V

3 = three phase, 230 V

4 = three phase, 460 V

5 = three phase, 575 V

### 7th Character - Impeller Diameter

A = 8.50"      E = 7.05"

B = 7.91"      G = 6.57"

C = 7.24"      H = 6.10"

D = 6.81"

### 8th Character - Cord Length

D = 30' (standard)

J = 100' (optional)

### 9th Character

X = Explosion Proof



Xylem Inc.  
2881 East Bayard Street Ext., Suite A  
Seneca Falls, NY 13148  
Phone: (866) 325-4210  
Fax: (888) 322-5877  
[www.gouldswatertechnology.com](http://www.gouldswatertechnology.com)

Goulds is a registered trademark of Goulds Pumps, Inc. and is used under license.  
© 2015 Xylem Inc. B4GVPLUS R3 August 2015