



4SD

SUBMERSIBLE SEWAGE PUMP
DUAL SEAL WITH SEAL SENSOR PROBE



FEATURES

Impeller: Cast iron, two vane semi-open, non-clog with pump-out vanes for mechanical seal protection. Balanced for smooth operation. Silicon bronze impeller available as an option.

Casing: Heavy duty cast iron, volute type for maximum efficiency. 4" flange conforms to 125 # ANSI standard. Connects to A10-40 or A10-60 guide rail system.

Dual Mechanical Seals: Silicon carbide vs. silicon carbide outer seal and ceramic vs. carbon inner seal, stainless steel metal parts, BUNA-N elastomers. Upper and lower shaft seals are positioned independently and are separated by an oil-filled chamber.

Seal Sensor Probe: Located in oil-filled chamber. If pumpage should begin to leak past lower seal it indicates to pump control panel a fault has occurred. **Requires optional Seal Fail Circuit in the control panel.**

Shaft: 300 series stainless steel keyed design.

Fasteners: 300 series stainless steel.

Capable of running dry without damage to components.

AGENCY LISTINGS



Tested to UL 778 and CSA 22.2 108 Standards
By Canadian Standards Association
File #LR38549

APPLICATIONS

Used in a variety of residential, commercial and industrial applications such as:

- Sewage systems
- Flood and pollution control
- Dewatering/Effluent
- Farms
- Hospitals
- Trailer courts
- Motels

SPECIFICATIONS

Pump:

- Maximum solid size: 3"
- Discharge size: 4", 125 # ANSI flange
- Maximum capacity: 620 GPM
- Maximum total head: 60 feet
- 300 Series stainless steel fasteners
- 20' Power cord
- Standard silicon carbide/silicon carbide outer seal

Motor:

- Maximum ambient temperature: 104° F (40° C) continuous duty, 140° F (60° C) intermittent duty
- Rated for continuous duty when fully submerged
- Insulation: Class F
- 60 Hertz
- Single row ball bearings
- 300 Series stainless steel keyed shaft

Single Phase:

- 1.5 - 5 HP
- 208 and 230 volts
- Built-in thermal overloads with automatic reset
- Built-in capacitors

Three Phase:

- 1.5 - 7.5 HP
- 200, 230, 460 and 575 volts
- Class 10 overload protection must be provided in control panel

MOTORS

- Fully submerged in oil-filled chamber. High grade turbine oil surrounds motor for more efficient heat dissipation, permanent lubrication of bearings and mechanical seal for complete protection against outside environment.
- **Class F insulation**
- **Designed for Continuous Operation:** Pump ratings are within the motor manufacturer's recommended working limits and can be operated continuously without damage when fully submerged.
- **Bearings:** Upper and lower heavy duty ball bearing construction for precision positioning of parts and to carry thrust loads.
- **Power and Control Cables:** Severe duty rated, oil and water resistant. Epoxy seal on motor end provides secondary moisture barrier in case of outer jacket damage and to prevent oil wicking. 20 foot standard with optional lengths available.
- **O-ring:** Assures positive sealing against contaminants and oil leakage.

MODEL AND MOTOR INFORMATION

Order Number	HP	Phase	Volts	RPM	Impeller		Maximum Amps	Locked Rotor Amps	KVA Code	Power Cable	F.L. Motor Efficiency %	Resistance		Weight (lbs.)
					Dia. (In.)	Code						Start	Line-Line	
4SD52F8EA	1.5	1	208	1750	5.63	E	17.2	50.8	B	14/3	80	1.1	0.9	195
4SD52F1EA			230				14.7	29.5	E		70	1.4	1.8	
4SD52F2EA		3	200				11.5	40.9	H	14/4	81	NA	1.7	
4SD52F3EA			230				10.0	40.0	F		83		2.3	
4SD52F4EA			460				5.0	20.0	F		83		9.3	
4SD52F5EA			575				4.0	14.4	H		74		14.8	
4SD52F8DA	1.5	1	208		6.25	D	17.2	50.8	B	14/3	80	1.1	0.9	195
4SD52F1DA			230				14.7	29.5	E		70	1.4	1.8	
4SD52F2DA		3	200				11.5	40.9	H	14/4	81	NA	1.7	
4SD52F3DA			230				10.0	40.0	F		83		2.3	
4SD52F4DA			460				5.0	20.0	F		83		9.3	
4SD52F5DA			575				4.0	14.4	H		74		14.8	
4SD52G8CA	2	1	208	6.63	C	20.3	50.8	B	14/3	80	1.1	0.9	200	
4SD52G1CA			230			17.3	36.9	D		75	1.4	1.5		
4SD52G2CA		3	200			13.3	40.9	H	14/4	81	NA	1.7		
4SD52G3CA			230			11.6	40.0	F		83		2.3		
4SD52G4CA			460			5.8	20.0	F		83		9.3		
4SD52G5CA			575			4.6	14.4	H		74		14.8		
4SD52H8BA	3	1	208	7.00	B	25.5	50.8	B	10/3	80	1.1	0.9	208	
4SD52H1BA			230			21.5	46.4	C		79	1.0	1.0		
4SD52H2BA		3	200			16.6	53.8	G	10/4	85	NA	1.3		
4SD52H3BA			230			14.4	49.5	H		83		1.9		
4SD52H4BA			460			7.2	24.8	H	14/4	83		7.5		
4SD52H5BA			575			5.8	17.3	G		78		11.6		
4SD52J1AA	5	1	230	7.25	A	26.5	57.7	A	10/3	80	1.0	0.8	213	
4SD52J2AA			200			19.1	73.9	F		10/4	84	0.9		
4SD52J3AA		3	230			16.6	63.6	E	14/4		85	NA	1.2	
4SD52J4AA			460			8.3	31.8	E		85	4.8			
4SD52J5AA			575			6.6	22.8	E	80	7.4				
4SD52K3FA			7.5			3	230	7.69	F	23.0	105.0		G	10/4
4SD52K4FA	460	11.5		52.5	G		83			2.8				
4SD52K5FA	575	9.2		42.0	E		84			4.4				

NOMENCLATURE DESCRIPTION

1st, 2nd and 3rd Character - Discharge Size and Type

4SD = 4" discharge, 3" solids handling, dual seal with seal fail probe in pump.

4th Character - Mechanical Seals

5 = Silicon carbide/silicon carbide/BUNA - lower seal and carbon/ceramic/BUNA - upper seal (standard)

3 = Silicon carbide/tungsten carbide/BUNA - lower seal and carbon/ceramic/BUNA - upper seal (optional)

5th Character - Cycle/RPM

2 = 60 Hz/1750 RPM 6 = 50 Hz/1450 RPM

6th Character - Horsepower

F = 1½ HP H = 3 HP K = 7½ HP

G = 2 HP J = 5 HP

7th Character - Phase/Voltage

1 = single phase, 230 V 4 = three phase, 460 V

2 = three phase, 200 V*5 = three phase, 575 V

3 = three phase, 230 V 8 = single phase, 208 V

* Not available on 7½ HP.

8th Character - Impeller Diameter

A = 7.25", 5 HP D = 6.25", 1½ HP

B = 7.00", 3 HP E = 5.63", 1½ HP

C = 6.63", 2 HP F = 7.69", 7½ HP

9th Character - Cord Length (Power and Sensor)

A = 20' (standard) F = 50'

D = 30' J = 100'

10th Character - Options

B = Bronze impeller

E = Epoxy paint

F = Both epoxy paint and bronze impeller

11th Character - Option

H = Pilot duty thermal sensors (3 phase only!!)

APPLICATION DATA

Maximum Solid Size	3"
Minimum Casing Thickness	5/16"
Casing Corrosion Allowance	1/8"
Maximum Working Pressure	30 PSI
Maximum Submergence	50 feet
Minimum Submergence	Fully submerged for continuous operation
	6" below top of motor for intermittent operation
Maximum Environmental Temperature	40°C (104°F) continuous operation
	60°C (140°F) intermittent operation

CONSTRUCTION DETAILS

Power Cable - Type	14/3, type SJTOW: single phase, 1/2 and 2 HP
	14/4, type STOW: single phase, 1 1/2 - 3 HP and 5 HP, 460 V
	10/4, type STOW: single phase, 3 and 5 HP, three phase 5 HP, 230 V and 7 1/2 HP
Sensor Cable - Type	16/2, type SJTOW: seal sensor only
	18/4, type SJTOW: seal/heat sensor
Motor Cover	Gray Cast Iron - ASTM A48 Class 30
Bearing Housing	Gray Cast Iron - ASTM A48 Class 30
Seal Housing	Gray Cast Iron - ASTM A48 Class 30
Casing	Gray Cast Iron - ASTM A48 Class 30
Impeller	Gray Cast Iron - ASTM A48 or Cast Bronze - ASTM B584 C87600
Motor Shaft	AISI 300 Series Stainless Steel
Motor Design	NEMA 56 Frame, oil filled with Class F Insulation
Motor Overload Protection	Single Phase: on winding thermal overload protection
	Three Phase: require ambient compensated Class 10, quick trip overloads in the control panel.
Motor Seal Fail (Moisture) Detection	Seal fail sensor in an oil-filled seal chamber. Connect to an optional relay in control panel.
Optional Motor Thermal Protection	Normally closed on-winding thermostats open at 275° F (135 °C) and close at 112° F (78° C). Require terminal connection in the control panel.
External Hardware	300 Series Stainless Steel
Impeller Type	Semi-open with pump out vanes on back shroud
Oil Capacity - Seal Chamber	1.75 quarts
Oil Capacity - Motor Chamber	1 1/2-5 HP single and three phase: 7 quarts
	7 1/2 HP three phase: 6.5 quarts

STANDARD PARTS

Ball Bearing	Upper	1 1/2 - 5 HP single and three phase: single row ball- SKF™ 6204-2Z 7 1/2 HP three phase: single row ball - SKF™ 6204-2Z
	Lower	1 1/2 - 5 HP single and three phase: single row ball - SKF™ 5206-2Z 7 1/2 HP three phase: double row ball - SKF™ 5206-2Z
Mechanical Seals - Standard	Upper	Carbon/Ceramic; Type 21
	Lower	Silicon Carbon/Silicon Carbon; Type 31
Mechanical Seals - Optional Lower		Silicon Carbide/Tungsten Carbide: Type 21
O-Ring - Stuffing Box		BUNA-N, AS 568A-265
O-Ring - Motor Cover		BUNA-N, AS 568A-374

DIMENSIONS

(All dimensions are in inches. Do not use for construction purposes.)

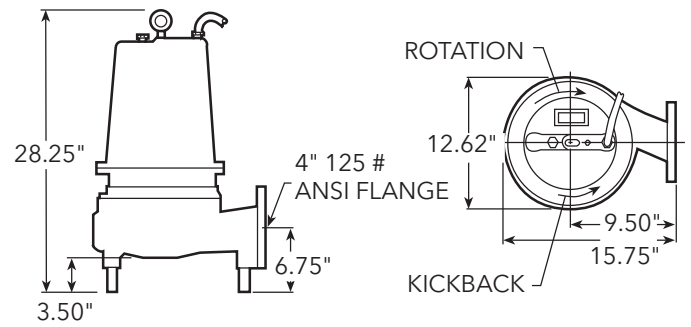

MATERIALS OF CONSTRUCTION

Item No.	Part Name	Material				
		Standard	Optional			
1	Impeller, non-clog	1003	1179			
2	Castings	1003				
3	Shaft-Keyed	300 Series SS				
4	Fasteners	300 Series SS				
5	Ball bearings	Steel				
6	Power cable	STOW, 20 feet	Additional lengths			
	Seal sensor cable					
7	O-ring	BUNA-N				
8	Outer Mech. Seal	Rotary	Stationary	Elastomers	Metal Parts	
	OPT	Heavy duty	Silicon Carbide	Tungsten Carbide	BUNA-N	300 Series SS
	STD	Mild abrasives	Silicon Carbide		BUNA-N	300 Series SS
Material Code		Engineering Standard				
1003		Cast iron - ASTM A48 Class 30				
1179		Silicon bronze - ASTM C87600				

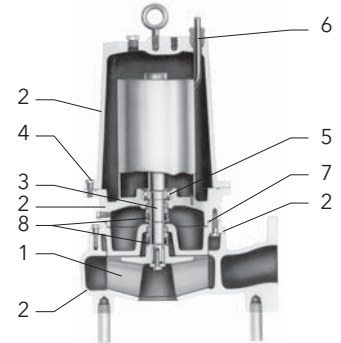

xylem
Let's Solve Water

Xylem Inc.
2881 East Bayard Street Ext., Suite A
Seneca Falls, NY 13148
Phone: (866) 325-4210
Fax: (888) 322-5877
www.gouldswatertechnology.com

Goulds is a registered trademark of Goulds Pumps, Inc. and is used under license.
© 2016 Xylem Inc. B4SD R2 June 2016