



Technical Specifications

Package Includes:..... Motor, Pump Tube, Hose, Storage Bracket, Barrel Adapter & Hand Nozzle

Motor Type:..... Open Drip Proof (IP44)

Pump Tube Material:.....SS316L, PTFE, Carbon Graphite

Immersion Length:..... 39" (1000 mm) or 47" (1200 mm)

Discharge Hose:PVC, 6 ft (1,8 m), 1" (25 mm) I.D.

Hand Nozzle Material: SS316, Viton

Maximum Flow Rate:..... 21 GPM (79 LPM) *based on water*

Maximum Viscosity: 1500 cps (mPas)

Maximum Temperature: 175° F (80° C)

Shipping Weight:..... 32 lbs. (14,51 kg)

RECOGNIZED COMPONENT



Intertek

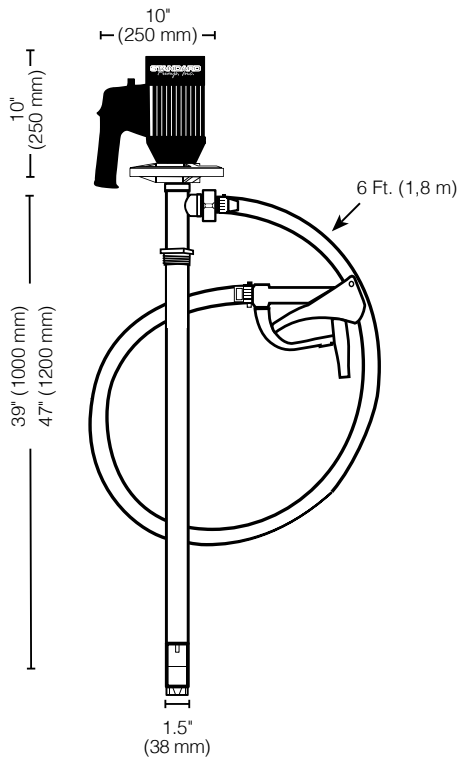

DRUMS

Package P/N	Motor	Volts	Pump Tube
9714	SP-280P-V	110V	SP-7600-39
9715	SP-280P-2-V	220V	SP-7600-39

TANKS

Package P/N	Motor	Volts	Pump Tube
9716	SP-280P-V	110V	SP-7600-47
9717	SP-280P-2-V	220V	SP-7600-47



Warning: This pump is not suitable for use with Flammable/Combustible liquids.

*Note: When pumping viscosities over 1,000 cps, pump must be used intermittently to avoid potential premature failure and/or damage.